



# The Uganda Medical and Dental Practitioners Council

**ANNUAL REPORT**  
**2017/2018**





# UMDPC ANNUAL REPORT 2017/2018

---

# TABLE OF CONTENTS

|  |    |
|--|----|
| Foreword.....  | 4  |
| Word From The Registrar.....   | 5  |
| Section 1: Introduction.....   | 6  |
| Vision.....  | 6  |
| Mission.....   | 6  |
| Values.....  | 6  |
| Functions of the Council.....  | 7  |
| Section 2: Governance And Management.....  | 8  |
| Members of Council.....  | 8  |
| Composition of the Council.....  | 9  |
| Ex- Officials.....   | 9  |
| Committees of the Council.....   | 9  |
| Council organogram.....  | 12 |
| Section3: Strategic Direction Of The Council.....  | 13 |
| Strategic Objectives of Council.....   | 14 |
| Reviewing and Approving Curricula.....   | 15 |
| Conducting inspection/support supervision of Medical training<br>institutions.....           | 18 |
| Production of Graduates.....   | 19 |
| University ethical sensitization.....  | 20 |
| Maintaining the register of students from the Medical & Dental<br>training institutions..... | 20 |
| Conducting Peer review.....  | 23 |
| Conducting support supervision and inspection of<br>health facilities.....                   | 23 |
| Conducting regional ethical sensitization.....   | 24 |
| District Health Supervisory Authorities (DHSA).....  | 25 |
| Facilitating the regional inspectors.....  | 26 |
| Hosting Medical Inquiries.....   | 26 |
| Registering and licensing practitioners.....   | 28 |
| Annual Practicing License (APL).....   | 29 |
| Temporary Registration.....  | 34 |
| Improving policy and regulatory frameworks.....  | 38 |
| Governance and Management.....   | 38 |
| ANNEX 1. COUNCIL DOCUMENTS.....  | 43 |
| ANNEX 2. UMDPC REGIONAL OFFICES & DISTRICS.....  | 44 |
| ANNEX 3. LIST OF PROVISIONALLY ACCREDITED CPD PROVIDERS<br>AS AT JUNE 2018.....              | 45 |

---

## FOREWORD



The Mission of the Council is “To regulate and enforce standards of education, training and practice in Uganda so as to protect society from harmful effects of malpractice”. Contained in this statement is the principle of quality. Council strives to ensure application and enforcement of quality in implementing its mandate especially in the area of professional education and training. To this end the Council has continued to work closely with the Ministry of Health, Ministry of Education and Sports, the National Council for Higher Education, and the various universities, starting from admission, through implementation of the curriculum and including Internship training. This effort has become particularly important as new Medical schools come on board, and also by the fact that Uganda is a signatory to the East African Community protocol on health that calls for mutual recognition of qualifications in the partner states.

Internship training continues to be a big challenge. This is attributed to the big numbers of graduates needing to be absorbed by the few internship training centres, and with less than optimum numbers of supervisors. The Council in collaboration with the Ministry of Health has developed Guidelines for Internship Training and the Checklist for Accreditation of the training sites. We believe that if this is fully implemented will result in great improvement of the outcomes.

An emerging concern is the issue of Medical Tourism. The MoH and the Council is engaged in trying to understand the magnitude, mechanism and the effects of this multi-Sectoral phenomenon. As this is on-going, guidelines for Referral of Patients Abroad, and the conducting of Medical Camps have been developed and is being implemented.

The Ministry of health and the professional regulatory Councils are in the final stages of developing and instituting the National Health Professional Regulatory Authority. This is an umbrella organization that will ensure an inter-disciplinary approach to regulation aimed at ensuring quality, efficiency and effectiveness. The report for this period outlines the achievements and challenges of the Council as it implements its Strategic Plan. With support from the relevant ministries and agencies and our development partners we shall continue to build on our successes and address the challenges. There is still much to be done.

A handwritten signature in black ink, appearing to read 'O. S. S. S.', with a stylized underline.

---

## WORD FROM THE REGISTRAR



Council commends all the health care providers in their effort to offer quality health services to all the citizens of Uganda.

Council has spent this financial to consolidate the system that has been built for years. The emphasis during this year was on strengthening inspection of health facilities.

Council continued funding the regional inspection activities that are done by our inspectors in the region.

Council came up with an innovation “peer inspection” where health facilities in the private sector provide specialists that inspect each under guidance of UMDPC. This activity covered all major health facilities in Kampala and it was well received.

Experiences will used to inspect other regions.

More effort also was spent in Wakiso and Mukono districts which equally has a large number of health facilities.

We have also increased stakeholder involvement that include those in regulations and in health provisions.

The following year Council plans to expand capacity at secretariat by recruiting more staff and expanding infrastructure.

Lastly, practitioners are informed that the licencing period at Council will now be commencing on Nov1 so as to fulfil the the deadline for APL application of 31<sup>st</sup> dec of each year

Council welcomes ideas that will enable it serve its stakeholders better.

A handwritten signature in blue ink, appearing to read 'Katumba Ssentongo Gubala'. The signature is fluid and cursive, with a large initial 'K'.

Dr Katumba Ssentongo Gubala/Registrar

---

## **SECTION 1: INTRODUCTION**

The Uganda Medical and Dental Practitioners Council is a body corporate with perpetual Succession and a common seal and may sue or be sued in its corporate name and, subject to an act of parliament Chapter 272 of 1996; it may do or suffer all other things and acts as bodies Corporate may lawfully do or suffer.

### **Vision:**

'A reputable regulatory body that ensures the safety and the quality of care for the population of Uganda'.

### **Mission:**

'UMDPC strives to set and enforce standards of medical and dental training and practice in Uganda, so as to promote safe and quality health care and protect the public from malpractice'.

### **Values**

The core values that UMDPC will espouse in the quest to implement its mandate and perform its functions are:

- Integrity
- Compassion
- Fairness
- Respect and
- Accountability

The underpinning principles are:

- Professionalism
- Equity
- Equality
- Quality
- Competence

---

## Functions of the Council:

Part II, Section 3 of the UMDPC Act 1996 provides for the functions of the Council which includes;

The functions of the Uganda Medical and Dental Practitioners' Council are to;

- (a) Monitor and exercise general supervision and control over and maintenance of professional medical and dental educational standards, including continuing education
- (b) Promote the maintenance and enforcement of professional medical and dental ethics
- (c) Exercise general supervision of medical and dental practice at all levels
- (d) Exercise disciplinary control over medical and dental practitioners
- (e) Protect society from abuse of medical and dental care and research on human beings
- (f) Advise and make recommendations to the Government on matters relating to the medical and dental professions
- (g) Exercise any power and perform any duty authorized or required by this Act or any other law
- (h) Disseminate to the medical and dental practitioners and public, ethics relating to doctor-patient rights and obligations
- (i) Perform any other function or act relating to medical or dental practice as the minister may direct, for the purposes of discharging its functions under this Act.

---

## SECTION 2: GOVERNANCE AND MANAGEMENT.

### Members of Council



Ass. Professor Okullo Joel -Chairman



Prof. Mayanja Harriet



Dr. Mwebesa Henry



Prof. Sarah Kiguli Walube



Dr. Mwangi Juliet



Kiwanuka Ben



Dr. Nfwatwa Lule



Dr. Kwizera Arthur

---

## Ex- Officials



**Dr Katumba Ssentongo  
Gubala**



**Dr. Nyankori Fred**

## Composition of the Council;

- Associate Professor Okullo Joel -Chairman
- Director General of Health Services-Dr. Mwebesa Henry
- Dr. Mayanja Harriet -Representative of the faculty of medicine (MUK)
- Dr. Mwanga Juliet -Representative of the faculty of medicine (MUST)
- Dr. Kiwanuka Ben - Representative of the Uganda Private Medical and Dental practitioners
- Prof. Kiguli Sarah -Representative of the Uganda Medical Association
- Dr. Kwizera Arthur -Representative of the Uganda Medical Association
- Dr. Ntwatwa Lule -Representative of the Uganda Dental Association

## Ex– Officials

- Dr. Katumba Ssentongo Gubala - Registrar
- Dr. Nyankori Fred - Deputy Registrar

## Committees of the Council

### ***(i) Finance and Administration***

#### Members

- Ass. Prof. Joel Hamilton Okullo - Chairperson
- Prof. Harriet Mayanja Kizza
- Dr. Bernard Mathias Kiwanuka

---

## ***(ii) Ethics and Disciplinary***

Members

- Prof. Harriet Mayanja Kizza - Chairperson
- Dr. Juliet Amumpaire Mwanga
- Dr. Bernard Mathias Kiwanuka

## ***(iii) Education and Training***

Members

- Prof. Sarah Kiguli Walube - Chairperson
- Prof. Harriet Mayanja Kizza
- Dr. Kwizera Arthur

## ***(iv) Fitness to Practice***

Members

- Dr. Bernard Mathias Kiwanuka – Chairperson
- Prof. Sarah Kiguli Walube
- Dr. Kwizera Arthur

## ***(v) Quality Assurance and Research***

Members

- Dr. Lule Ntwatwa- Chairperson
- DGHS
- Dr. Juliet Amumpire Mwanga

## ***(vi) Inspection and Registration***

Members

- Dr. Juliet Amumpire Mwanga – Chairperson
- Dr. Lule Ntwatwa
- Dr. Kwizera Arthur

---

## 1. Sub Committee members

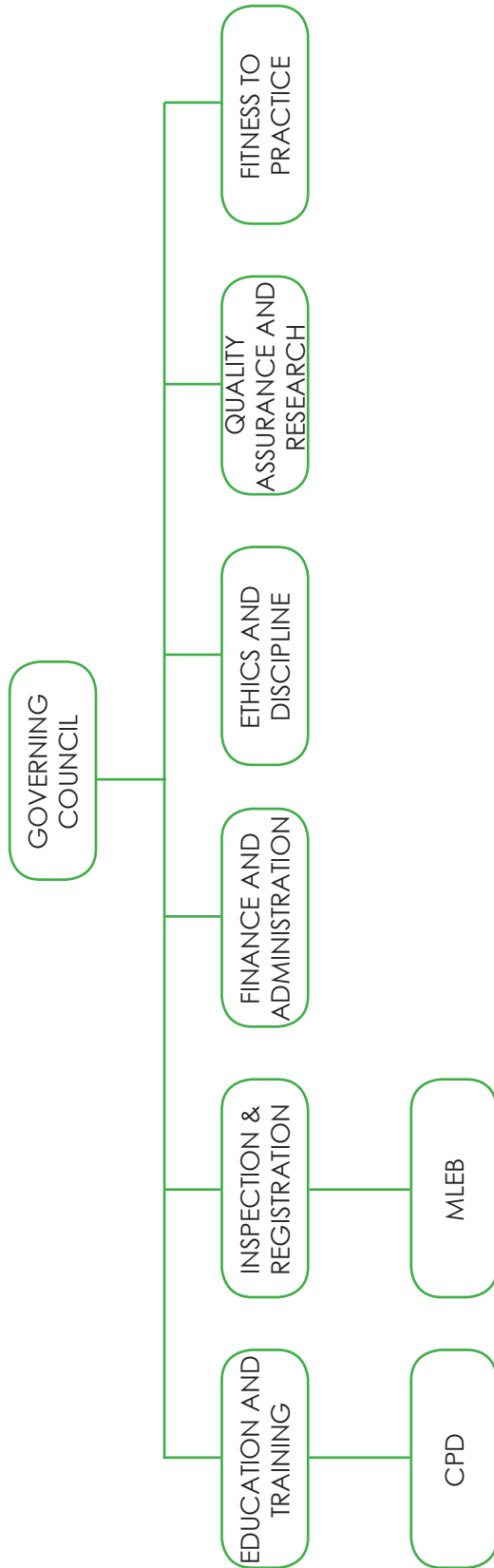
### a) *Medical Licensure and Examination Board*

- Dr. Agatha Nambuya -Chairperson
- Dr. Nakwagala Fred,
- Dr. Christine Biryabarema,
- Dr. Lawrence Kazibwe
- Dr. Eric Wobudeya,
- Dr. Aanyu Hellen,
- Dr. Kimuli Timothy,
- Dr. Louis Muwazi
- Dr. Annet Kutesa.

### b) *CPD Committee*

- Prof. Luboga Sam-Chairman
- Dr Mupeere Ezekiel
- Dr Kagawa Mike
- Dr. Muwazi Louis
- Dr Magala James
- Dr Kawanguzi Peter
- Dr Ocama Ponsiano
- Dr Kituuka Oliva
- Mr Isabirye Charles.
- Dr. Oriokot Francis

## COUNCIL ORGANOGRAM



---

## SECTION 3: STRATEGIC DIRECTION OF THE COUNCIL.

This section sets out the strategic direction of Uganda Medical and Dental Practitioners' Council. The choices address the core function for which UMDPC was established.

**Goal:** The overall goal of this strategy is to contribute to the improvement of quality medical and dental training and practice for a healthy and productive society.

The strategic directions formulated to address the core functions of UMDPC are:

**SD 1.** Promoting & monitoring standards of professional education, training and practice in Uganda.

**SD 2.** Enhancing quality assurance and compliance with professional practice standards

**SD 3.** Developing and reviewing key policy and regulatory frameworks

**SD4.** Strengthening and developing capacities of the Council for effectiveness and efficiency.

Under each of the strategic directions, strategic objective(s) have been developed with key priority areas of focus to guide the implementation process.

### **Result areas**

Standards of professional education, training and practice in Uganda monitored and strengthened.

- (i) Standards of Professional Education and training in various training institutions promoted and monitored.
- (ii) Quality assurance and compliance with professional practice standards enhanced.
- (iii) Key policy and regulatory frameworks developed and reviewed.
- (iv) Capacity of UMDPC secretariat built to effectively perform its functions.

## Strategic Objectives of Council.

### OBJECTIVE 1:

Standards of Professional Education and training in various training institutions promoted and monitored.

This key result area (KRA) aimed at promoting Professional education and training in various training institutions in Uganda. An important component of this KRA is internship. Here under is the list of approved medical and dental schools.

Table 1. MEDICAL AND DENTAL TRAINING INSTITUTIONS RECOGNISED BY UMDPC FOR THE FY 2017/2018

| S/n                 | UNIVERSITY                                     | LOCATION | UNDER GRADUATE       | POST GRADUATE  |
|---------------------|--|----------|----------------------|--|
| 1-                  | MAKERERE UNIVERSITY COLLEGE OF HEALTH SCIENCES | Kampala  | 1-MBChB              | M.Med Emergency Medicine                             |
|                     |  |          |                      | M. Med: Internal Medicine                            |
|                     |  |          |                      | M.Med Family Medicine                                |
|                     |  |          |                      | M.Med Microbiology                                   |
|                     |  |          |                      | M.Med Ophthalmology                                  |
|                     |  |          |                      | M.Med Paediatrics and Child Health                   |
|                     |  |          |                      | M.Med Pathology                                      |
|                     |  |          |                      | M.Med Psychiatry                                     |
|                     |  |          |                      | M.Med Radiology                                      |
|                     |  |          |                      | M.Med Ear, Nose & Throat                             |
|                     |  |          |                      | M.Med General Surgery                                |
|                     |  |          |                      | M.Med Obstetrics & Gynaecology                       |
|                     |  |          |                      | M.Med Anaesthesia                                    |
|                     |  |          |                      | M.Med Orthopaedic Surgery                            |
|                     |  |          | MSc in Human Anatomy |  |
| MSc in Pharmacology |  |          |                      |  |
| MSc in Physiology   |  |          |                      |  |
|                     |  |          | 2-BDS                | Master of Dentistry (Oral and Maxillofacial Surgery) |
| 2-                  | MBARARA UNIVERSITY OF SCIENCE AND TECHNOLOGY   | Mbarara  | MBChB                | 1-MMed Surgery                                       |
|                     |  |          |                      | 2-MMed-Med   |
|                     |  |          |                      | 3-MMed-Paediatrics                                   |
|                     |  |          |                      | 4-MMed-Obgy  |
|                     |  |          |                      | 5-MMed-ophthamology                                  |
|                     |  |          |                      | 6-MMed-Anaesthesia                                   |
| 3-                  | GULU UNIVERSITY                                | Gulu     | MBChB                | 1-MMed-Surgery                                       |

|     |   |          |              |  |
|-----|---|----------|--------------|--|
| 4-  | BUSITEMA UNIVERSITY                               | Tororo   | MBChB        | None   |
| 5-  | KAMPALA INTERNATIONAL UNIVERSITY UNIVERSITY (KIU) | Bushenyi | MBChB        | 1- Mmed Surgery<br>2- Mmed Obs/Gyn<br>3- Mmed Internal medicine<br>4- Mmed Peadiatrics |
| 6-  | ISLAMIC UNIVERSITY IN UGANDA (IUIU)               | Kampala  | MBChB        | None   |
| 7-  | ST. AUGUSTINE INTERNATIONAL UNIVERSITY (SAIU)     | Kampala  | MBChB        | None   |
| 8-  | UGANDA CHRISTIAN UNIVERSITY                       | Mengo    | MBChB<br>BDS | None   |
| 9-  | KABALE UNIVERSITY                                 | Kabale   | MBChB        |  |
| 10- | UGANDA MARTYRS UNIVERSITY NKOZI- NSAMBYA CAMPUS   | Kampala  |              | M. Med: Internal Medicine  |
|     |   |          |              | M.Med Paediatrics and Child Health   |
|     |   |          |              | M.Med General Surgery  |
|     |   |          |              | M.Med Obstetrics &Gynaecology  |
|     |   |          |              | M.Med Emergency Medicine   |

## 1.1 Reviewing and Approving Curricula.

The Uganda Medical and Dental Practitioners' Council is mandated to ensure that training for Medical and Dental practitioners in Uganda meet the required standards and curriculum review is one of the key undertakings by Council, within its broad function to regulate training, and practice of Medicine and Dentistry.

Council reviews curriculum for Medical and Dental training programs at the Universities on behalf of National Council for Higher Education (NCHE) every five (5) years.

In 2017/2018 Financial year, Council received 03 programs, reviewed 03 programs. There are still delays among the stakeholders involved in the curricula reviews, efforts are underway to streamline this bottleneck.

Below is the breakdown;

**TABLE2. LIST OF CURRICULA HANDLED BY COUNCIL IN THE FY 2017/2018.**

| Program                          | University          | Status             | Comment  |
|----------------------------------|---------------------|--------------------|--|
| MBChB                            | IUIU                | Accredited         | Program on ongoing                                   |
| MBChB                            | SAIU                | Accredited         | Program on ongoing                                   |
| MBChB                            | Busitema University | Ready for review 2 | Program on ongoing                                   |
| MMed (Internal Medicine)         | UMU Nsambya         | Rev. 2, Done       | Program on going                                     |
| MMed (Emergency Medicine)        | UMU Nsambya         | Rev. 2, Done       | Program on ongoing                                   |
| MMed (Paed and Child Health)     | KIU                 | Rev 2, Done        | Report presented to Education and Training Committee |
| MMed (Paed and Child Health)     | Busitema University | Rev 2, Done        | Report sent to NCHE                                  |
| MMed (Paed and Child Health)     | Kabale University   | Review 1 done      | Comment sent to the University                       |
| MMed (Psychiatry)                | KIU                 | Sent for review 1  | Another copy   |
|                                  |                     | No copy            |  |
| MMed (Surgery)                   | KIU                 | Review 2 done      | Report sent to NCHE                                  |
|                                  |                     | No copy            |  |
| MMed (Obs & Gynae)               | Kabale University   | Review 1 done      | Awaiting review 2 from the University                |
| MMED( Ophthalmology)             | KIU                 | Sent for review    | Remind reviewer                                      |
| BDS                              | KIU                 | Rev 1 done         | Awaiting review 2 from the University                |
|                                  |                     | Rev 1 done         |  |
| MMED (Emergency Medicine)        | MUST                | Review 2 done      | Report sent to NCHE                                  |
|                                  |                     | Review 1 done      |  |
| MBCHB                            | Kabale University   | Review 1 done      | Comment sent to the University                       |
|                                  |                     | Review 1 done      |  |
| Fellowship of Physicians of ECSA | Zambia              | Review 1 done      | To Registrar   |
| MMED (Dermatology)               | MUST                | Review 1 done      | Comment sent to the University                       |
| MMED Internal Medicine           | MUST                | Review 1 done      | Comment sent to the University                       |
| MSc Anatomy                      | MUST                | Review 1 done      | Comment sent to the University                       |
| MMed Pathology                   | MUST                | Review 1 done      | Comment sent to the University                       |

|                        |                   |               |   |
|------------------------|-------------------|---------------|---|
| MMed Ophthalmology     | MUST              | Review 1 done | Comment sent to the University            |
| MMed Biochemistry      | MUST              | Review 1 done | Comment sent to the University            |
| MMed Microbiology      | MUST              | Review 1 done | Comment sent to the University            |
| MMed Radiology         | MUST              | Review 1 done | Comment sent to the University            |
| BDS                    | UCU Mukono        | Review 2 done | Comment sent to the University            |
| MMed (Obs & Gynae)     | MUST              | Review 1 done | Comment sent to the University            |
| MMed (Surgery)         | MUST              | Review 2 done | Comment sent to the University            |
| MMED (FM)              | MUST              | Review 2 done | Comment sent to the University            |
| MBChB                  | UCU               | Review 2 done | Comment sent to the University            |
| MMed Paediatrics       | MUST              | Review 2      | Comment sent to University                |
| MBChB                  | MUST              | Review 1      | Comment to be sent to University          |
| MBChB                  | GULU              | Review 1      | Comment sent to NCHE                      |
| MMed Neurosurgery      | SAIU              | Review 1      | Comment to be sent to University          |
| MMed Internal Medicine | SAIU              | Review 1      | Comment to be sent to University          |
| MMed Em. Medicine      | MUK               | Review 2      | Comment to be sent to Education committee |
|                        |                   | Review 2      |   |
| BDS                    | KIU               | Review 3      | Comment to be sent to Education committee |
| MMed Pathology         | KIU               | Review 2      | Comment sent to University                |
|                        |                   | Review 1      |   |
| MMed Surgery           | KIU               | Review 1      | Sent for review                           |
| MMed Paediatrics       | KIU               | Review 1      | Sent for review                           |
| MMed Obs/Gyn           | KIU               | Review 1      | Sent for review                           |
| MMed Internal Medicine | KIU               | Review 1      | Sent for review                           |
| MBChB                  | Soroti University | Review 1      | Sent for review                           |

The partnership with NCHE has greatly improved. Council sat with NCHE in 4 strategic meeting meetings of mutual interest.

## 1.2 Conducting inspection/support supervision of Medical training institutions.

### Soroti Medical School

Council working with NCHE twice inspected the proposed Soroti medical school, and found it wanting in certain key areas. More inspections will be done before its approved.

### Kabale Medical School

Council also inspected and approved Kabale Medical School for the MBChB programme within this reporting period

### Uganda Christian University Medical School

The above named institution was inspected and approved by a joint UMDPC/ NCHE to commence medicine and dentistry programmes.

### Busitema Medical School

Council inspected and approved the medical school to commence a paediatrics postgraduate programme.

### Makerere Dental School

Council visited Makerere Dental School to assess its readiness to be re-inspected by the Joint East African Medical and dental Boards/Councils. Council was happy with the progress made by the University in terms of infrastructure development.

### TABLE 3. APPROVED MEDICAL AND DENTAL SCHOOLS WITHIN EAST AFRICAN COMMUNITY BY 2018

The table below gives an updated list of Medical and dental schools within East Africa, which were jointly inspected and approved by an East African group made up of the various councils/boards

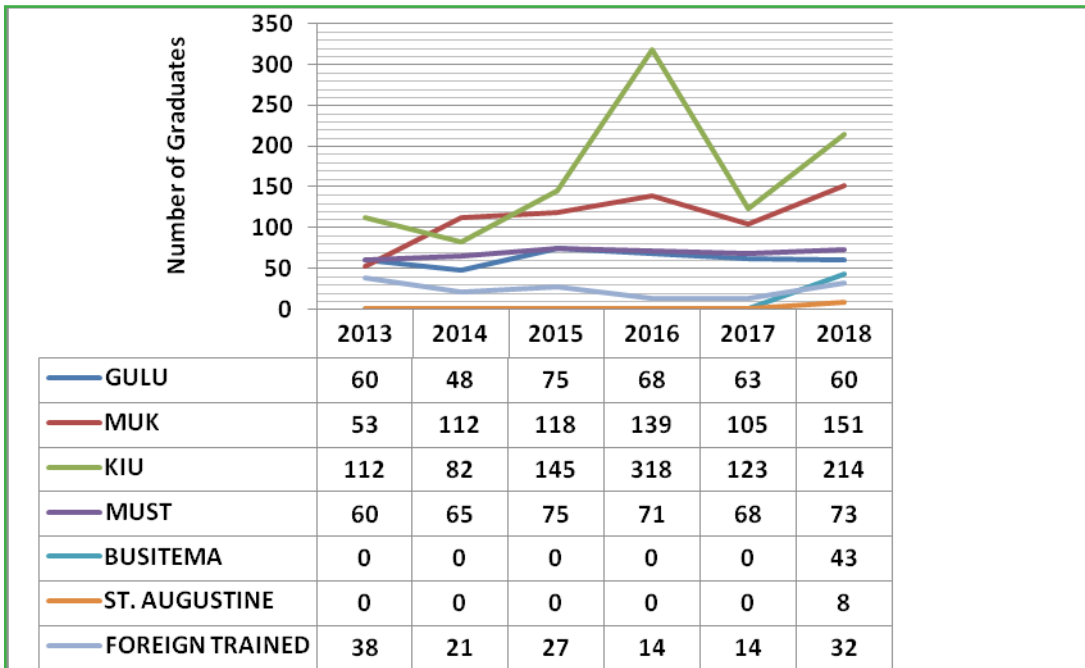
| S/n | UNIVERSITY                                  | LOCATION        | PROGRAM              |
|-----|---|-----------------|----------------------|
|     | <b>UGANDA</b>                               |                 |                      |
| 1.  | MAKERERE UNIVERSITY                         | KAMPALA         | MEDICINE & DENTISTRY |
| 2   | MBARARA UNIVERSITY OF SCIENC AND TECHNOLOGY | MBARARA         | MEDICAL              |
| 3.  | BUSITEMA UNIVERSITY                         | MPALE           | MEDICAL              |
| 4.  | GULU UNIVERSITY                             | GULU            | MEDICAL              |
| 5.  | ISLAMIC UNIVERSITY IN UGANDA                | KAMPALA         | MEDICAL              |
| 6.  | KAMPALA INTERNATIONAL UNIVERSITY            | ISHAKA/BUSHENYI | MEDICAL              |
| 7.  | ST AUGUSTINE INTERNATIONAL UNIVERSITY       | KAMPALA         | MEDICAL              |

| S/n             | UNIVERSITY                          | LOCATION   | PROGRAM            |
|-----------------|-------------------------------------|------------|--------------------|
| <b>KENYA</b>    |                                     |            |                    |
| 1.              | UNIVERSITY OF NAIROBI               | NAIROBI    | MEDICAL AND DENTAL |
| 2.              | KENYATTA UNIVERSITY                 | NAIROBI    | MEDICAL            |
| 3.              | JOMO KENYATTA UNIVERSITY            | NAIROBI    | MEDICAL            |
| 4.              | MASENO UNIVERSITY                   | MASENO     | MEDICAL            |
| 5.              | MOI UNIVERSITY                      | ELDORET    | MEDICAL AND DENTAL |
| 6.              | EGERTON UNIVERSITY                  | NAKURU     | MEDICAL            |
| 7.              | MOUNT KENYA UNIVERSITY              | KIAMBU     | MEDICAL            |
| 8.              | KENYA METHODIST UNIVERSITY          | MERU       | MEDICAL            |
| <b>TANZANIA</b> |                                     |            |                    |
| 1.              | MUHIMBILI UNIVERSITY                | DARESSALAM | MEDICAL            |
| 2.              | DODOMA UNIVERSITY                   | DODOMA     | MEDICAL            |
| 3.              | TUMAINI UNIVERSITY                  | MOSHI      | MEDICAL            |
| 4.              | CATHOLIC UNIVERSITY                 | MWANZA     | MEDICAL            |
| 5.              | STATE UNIVERSITY OF ZANZIBAR        | ZANZIBAR   | MEDICAL            |
| 6.              | HURBERT KAIRUKI MEMORIAL UNIVERSITY | DARESSALAM | MEDICAL            |
| <b>RWANDA</b>   |                                     |            |                    |
| 1.              | NATIONAL UNIVERSITY OF RWANDA       | KIGALI     | MEDICAL AND DENTAL |
| <b>BURUNDI</b>  |                                     |            |                    |
| 1.              | UNIVERSITY OF BURUNDI               | BUJUMBURA  | MEDICAL            |
| 2.              | NGOZI UNIVERSITY                    |            | MEDICAL            |
| 3.              | HOPE AFRICA UNIVERSITY              | BUJUMBURA  | MEDICAL            |

### 1.3 Production of Graduates

This reporting period there was a reduction in the production of graduates from 729 (2017) to 521 (2018). Council has guided that medical schools should handle students according to the capacity they have in terms of infrastructure and human resource. However two new medical schools of Busitema and SAIU graduated their first batch. Hereunder is the table showing the production of graduates from each University.

**TABLE 4. THE NUMBER OF GRADUATES WHO GRADUATED FROM EACH UNIVERISTY.**



### 1.3.1 Internship training

List of the approved training sites is attached as appendix 1.

### 1.4 University ethical sensitization:

Ethics sensitization in Medical and Dental Schools

In this period , Council conducted ethical trainings to undergraduate students in Makerere University. This sensitization was aimed at inducting the students into the etiquette of the profession. It is recommended that all graduates undergo a two day orientation workshop where further awareness to ethical issues is routinely provided annually.

### 1.5 Maintaining the register of students from the Medical & Dental training institutions:

Council is still following the matter of indexing all students in the medical schools. This aims at tracking the intake, progress and outputs of each University. Only Gulu University has so far complied. Council is working with NCHE to ensure that this quality assurance measure is strictly adhered to. Student indexing is important in enabling the Council to track the progress of its students and also provides data for planning for internship and later deployment

---

## OBJECTIVE 2:

Quality Assurance and compliance with professional practice standards.

### 2.1 Facilitating Continuous Professional Development (CPD):

Council has continued to progress on managing and monitoring the CPD function. More centres have been accredited during this period. Council maintains non-licencing of practitioners without evidence of CPD. More centres are still being called upon to apply for accreditation especially in rural areas.

The list of accredited providers is shared through with the Partner East African Community Medical Councils and Boards, so that Credits can be transferred in the region.

Council also revised the CPD guidelines in order to cater for groups of practitioners who had not been catered for earlier.

Council plans to electronise CPD and phase out the legendary CPD books which are bulky.

### 2.2 Registration of foreign trained Doctors.

#### 2.2.1 Conducting Medical Licensure and Examinations (MLEB).

Council has continued to conduct exams for all foreign trained graduates wishing to practice medicine or dentistry in Uganda at both degree and specialist levels. This practice is now a norm in the all the EAC partner states and now spreading to all African partners. The exam consists of a written and clinical section. One must pass the written paper before proceeding to the clinical exam.

Under the East African protocol, the Council only recognizes qualifications obtained from Universities within East Africa, which are also recognized by the joint East African Community Councils and Boards as shown below

**TABLE4. ALL PRACTITIONERS FROM EAC PARTNER STATES**

| COUNTRY  | MALE | FEMALE | TOTAL |
|----------|------|--------|-------|
| BURUNDI  | 5    | 4      | 9     |
| KENYA    | 41   | 24     | 65    |
| RWANDA   | 17   | 5      | 22    |
| TANZANIA | 14   | 13     | 27    |

**TABLE 5. PRACTITIONERS TRAINED WITHIN COUNTRY OF ORIGIN**

| COUNTRY  | MALE | FEMALE | TOTAL |
|----------|------|--------|-------|
| BURUNDI  | 4    | 3      | 7     |
| KENYA    | 24   | 11     | 35    |
| RWANDA   | 15   | 5      | 20    |
| TANZANIA | 7    | 6      | 13    |

Council has noted in the academic transcripts submitted, that some training schools allocate very few hours to training especially in the basic sciences. Council plans to visit some of the training schools abroad to verify the quality of training in those institutions.

In 2018, Out of the twenty four (24) candidates who presented themselves for the written exams, 12 Candidates passed and the other 12 failed as indicated below.

**TABLE6. MLEB PERFORMANCES BY JUNE 2018.**

| COUNTRY | NO | PASSED | FAILED |
|---------|----|--------|--------|
| CHINA   | 13 | 07     | 06     |
| UKRAINE | 01 | 01     | 00     |
| RUSSIA  | 02 | 00     | 02     |
| SUDAN   | 04 | 02     | 02     |
| ALGERIA | 03 | 02     | 01     |
| AMERICA | 01 | 00     | 01     |
| TOTAL   | 24 | 12     | 12     |

**TABLE 7. MLEB PERFORMANCES FROM 2012 TO DATE.**

| COUNTRY   | NO | PASSED | FAILED |
|-----------|----|--------|--------|
| CHINA     | 42 | 33     | 9      |
| UKRAINE   | 26 | 26     | 0      |
| RUSSIA    | 19 | 17     | 02     |
| SUDAN     | 17 | 15     | 02     |
| ALGERIA   | 13 | 12     | 01     |
| KAZAKSTAN | 5  | 5      | 0      |
| CUBA      | 4  | 4      | 0      |
| DRC       | 2  | 2      | 0      |
| INDIA     | 1  | 1      | 0      |
| MAURITUS  | 1  | 1      | 0      |
| ROMANIA   | 1  | 1      | 0      |

| COUNTRY  | NO | PASSED | FAILED |
|----------|----|--------|--------|
| ERITREA  | 1  | 1      | 0      |
| S.SUDAN  | 1  | 1      | 0      |
| MALAYSIA | 1  | 1      | 0      |
| PAKISTAN | 1  | 1      | 0      |
| AMERICA  | 1  | 0      | 01     |

### 2.2.2 Conducting Peer review.

Council will continue to examine all foreign registered and specialists using a peer review approach. To ensure that all practitioners are covered, Council revised the peer review guidelines in this reporting period 2017/18 and now all practitioners registered outside Uganda and are wishing to practice in the Country will do peer reviews.

**TABLE 8. STATUS OF PEER REVIEWED PRACTITIONERS 2017/18.**

| OUTCOME                  | NUMBER OF PRACTITIONERS |
|--------------------------|-------------------------|
| Registered as GP         | 5                       |
| Registered as Specialist | 11                      |
| Not Registered           | 2                       |
| Internship               | 3                       |
| Attached                 | 5                       |
| Appealed                 | 5                       |

### 2.3 Conducting support supervision and inspection of health facilities.

One of the functions of UMDPC is regulation of practice of medicine and dentistry in order to improve quality of health services delivery and ensure patients' safety.

The UMDPC annually plans for and conducts routine inspection of health units in the districts and Kampala area to ensure that existing health units and the persons running them are registered with the Council and they meet the recommended standards of practice..

In conformity with Section 32 (1) of the UMDP Act, the Council under a special program code named peer to peer review inspected 27 main hospitals units in the 5 divisions of Kampala including Central, Nakawa, Makindye, Kawempe and Rubaga and conducted support supervision in several districts within the 13 regional centres.

The consultants engaged were specialists drawn from the major public and private facilities within Kampala. This exercise promoted support supervision and collegiality among practitioners and health facilities.

Council also inspected facilities in Mukono and Wakiso municipalities of Nansana, Makindye Sabagabo and Kiira.

However challenges remain with illegal clinic and quack practitioners.

The joint registrars forum has issued a joint communiqué that will be used to handle some of the major bottlenecks found in this inspection.



***Preparatory Meeting for the peer to peer inspection of Kampala Metropolitan private Hospitals***

## **2.4 Conducting regional ethical sensitization**

It is important to observe that the number of complaints received by the council is rising every year. This may be partly attributed to increased public awareness of patients' rights as a result of improved information sharing using social media and world-wide exposure as one travels for medical treatment.

The increase in complaints may also mean deterioration in standards of health care delivery on the part of practitioners and failure to understand their responsibility in different situations in clinical practice.



*Sensitization of regional stakeholders in Eastern Uganda.*

## **2.5 District Health Supervisory Authorities (DHSA)**

The joint health professional councils created the DHSA to improve on their supervisory roles and to increase on their visibility on the ground. DHSAs are formed from representations of professionals from their respective Councils. Council has been engaging them as they work with our regional inspectors.

Regulatory Councils with support from Strengthening Human Resources for Health (SHRH), organized dissemination of Council documents to stakeholders in Soroti and Mbale District by April 2018. The stakeholders included RDCs, CAOs, District Chairpersons, DPCs, DHOS and DISOs.

Joint health professional councils still need more funding to fully support these agencies.



*One of the dissemination meetings held by Joint councils in Mbale*

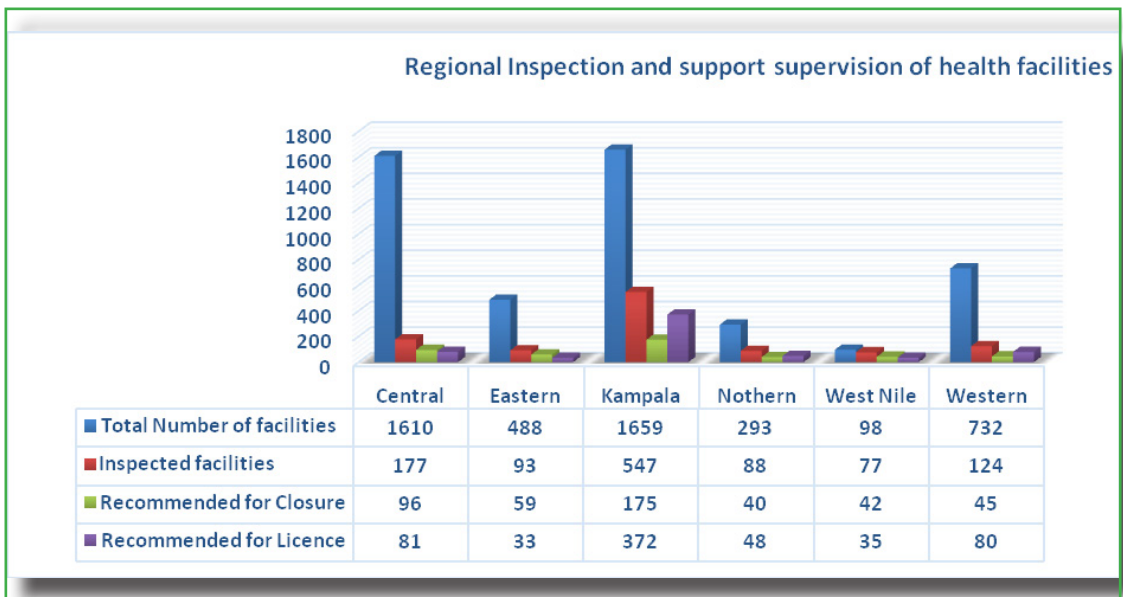
## 2.6 Facilitating the regional inspectors;

UMDPC is working within its inspectorate areas, that is, the Buganda, Kampala, Bugisu, Bukedi, Teso, Lango, Kigezi and Tooro. Over 500 health facilities were inspected under this arrangement.

On a regular basis, they are invited to beef up the Kampala inspection and they have been very effective in inspection and supervision. They are also working with the District Supervisory Authorities. However this strategy is faced with lack of transport and infrastructure.

The summary of the inspections are as below;

**Graph 1. Showing regional inspection of Health Facilities by 2018.**



## 2.7 Hosting Medical Inquiries

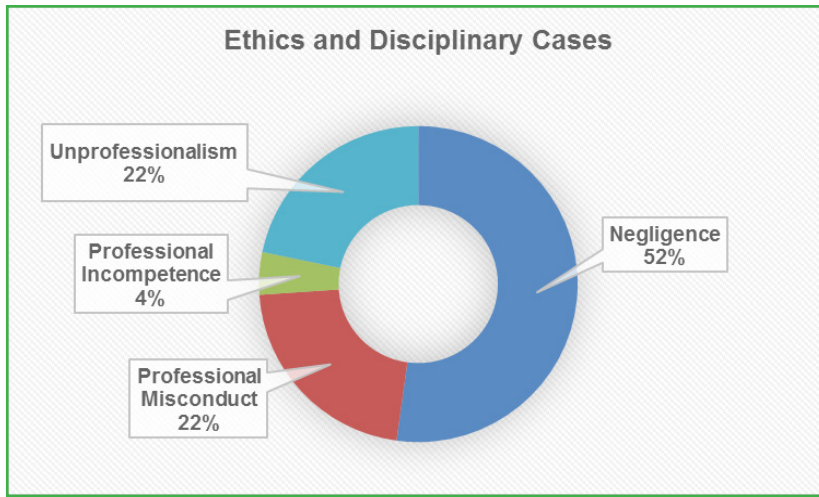
### 2.7.1 Ethics and disciplinary

Practitioners who have offences leveled against them are brought to Council .The offences under this category included negligence, false recording and general professional misconduct.

Number of cases reported 2017/2018= 20

Number of inquiries conducted = 4

**Fig1. Matters/cases handled by the ethics & disciplinary committee for the period 1<sup>st</sup> July 2017 to 30<sup>th</sup> June 2018.**

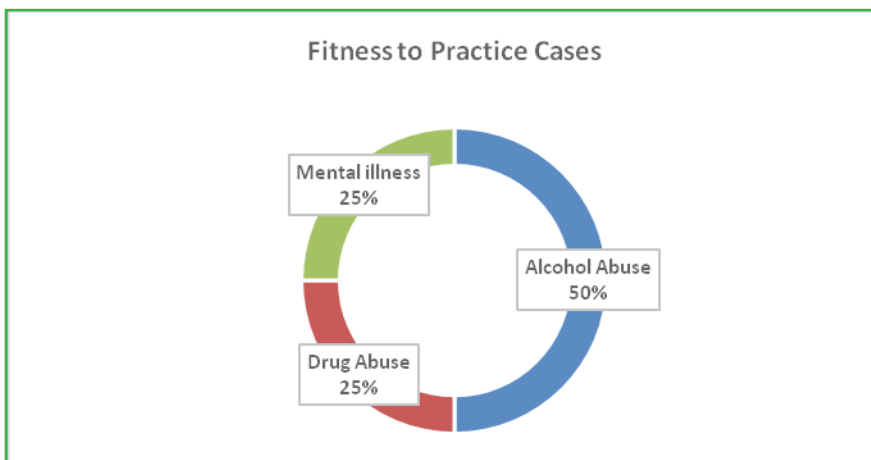


**2.7.2 Fitness to Practice**

Fitness to practice is based on principle that for one to practice one must be physically and mental sound so as to engage himself/herself in the care of patients and clients seeking assistance.

UMDPC has made inroads especially in identifying impaired practitioners. To this end we continue to appeal to colleagues to be “or brother’s keeper”. We do not have figures as to how many of our doctors are affected and what the main causes are. But alcohol, drugs, ill-health and ageing seem to be the main factors (see Chart below). Unfortunately one practitioner who objected care and rehabilitation was de-registered by Council as per the law.

**Fig 2. Matters/cases handled by the fitness to practice committee for the period 1<sup>st</sup> July 2017 to 30<sup>th</sup> June 2018.**



## 2.8 Registering and licensing practitioners;

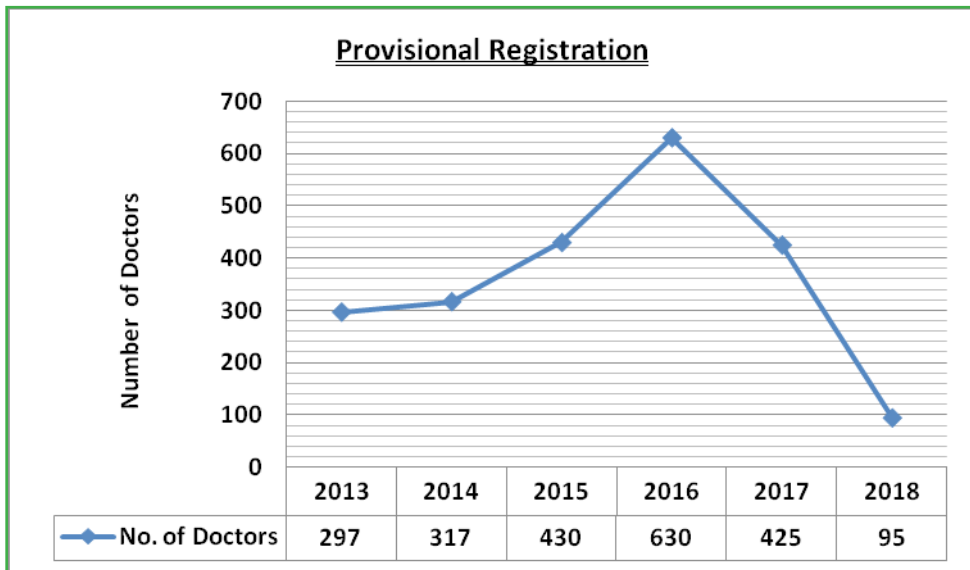
Registers for Medical and Dental professionals and health units have been properly maintained as detailed below;

### 2.8.1 Provisional registration.

Provisional registration refers to registration of eligible persons who do not qualify to be registered by reason only that he or she does not have the experience required under section 17(2) of the UMDPC Act. This is usually given to those registered for internship training. Council will continue to sensitize interns and other stakeholders to ensure full compliance to this requirement before one commences internship.

UMDPC provisionally registered 581 Medical and Dental Practitioners in this period.

**Graph 2. Showing provisional Registration Certificate.**



### 2.8.2 Full Registration

Full registration refers to registration of eligible Ugandan Nationals holding a Bachelor of Medicine and Surgery or Bachelor of Dental Surgery degree after successful completion of internship. Record of Doctors with full registration status is maintained in the main register of the UMDPC in Form 1 set out in the Second Schedule.

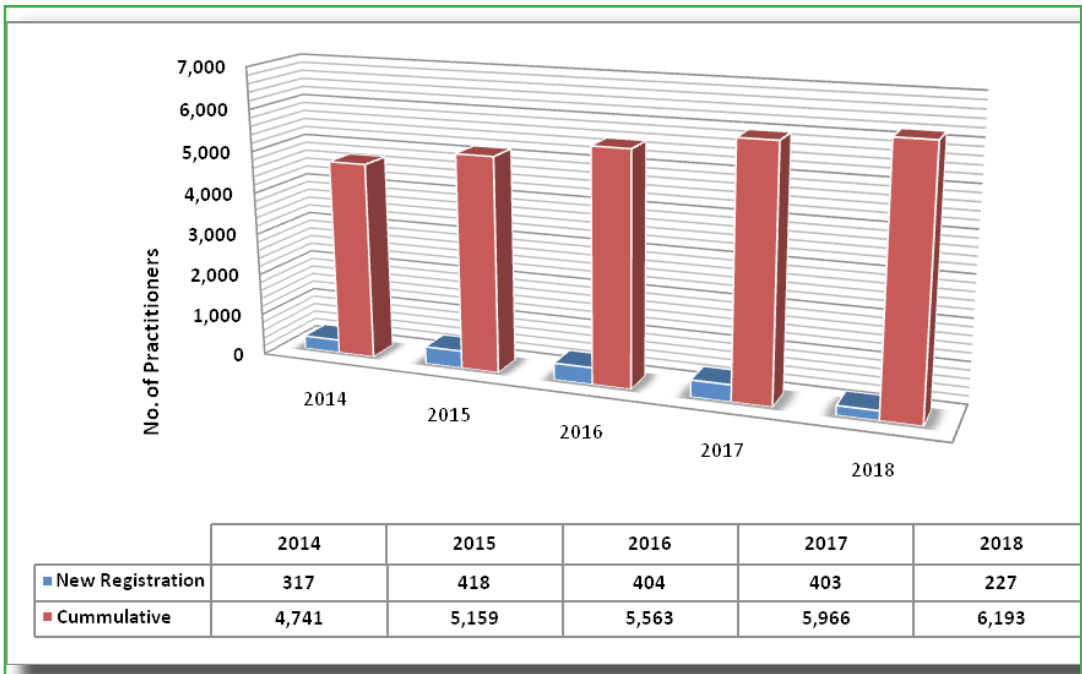
**Council under the revised Act has provided for a retention register where those who are not in active clinical practice can be maintained.**

353 practitioners were registered at the Council from July 2017 to June 2018. This gives a cumulative number of 6193, to date.

The Number of Dental Surgeons in the country is still low that is 286 Practitioners by June 2018. This translates into a ratio of 1: 139,860 (1 Dental Surgeon for every 139,860 people). There only 16 specialized dentists in the country.

**Ministry of Health and Education needs to prioritize the training of dentistry at both under graduate and post graduate levels in order to provide quality dental services in the country.**

**Graph 3. Showing Full Registration Certificates.**

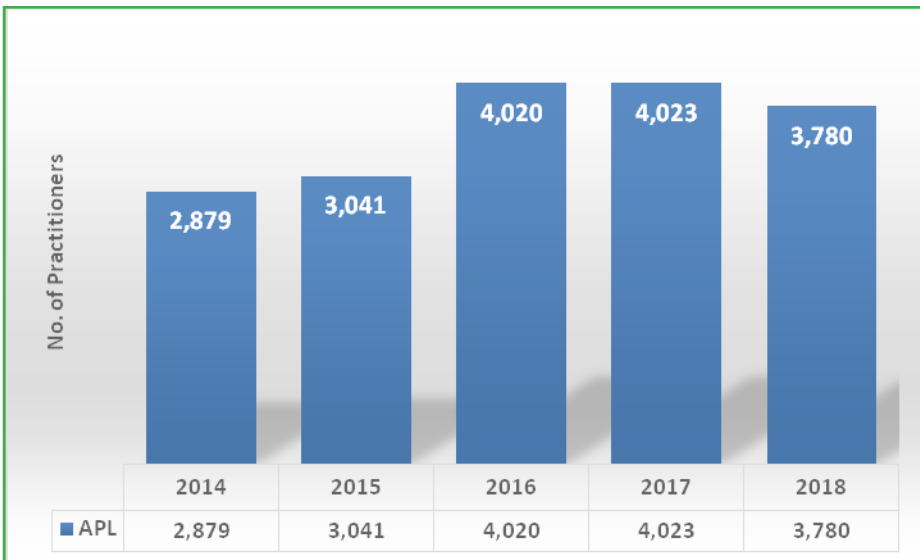
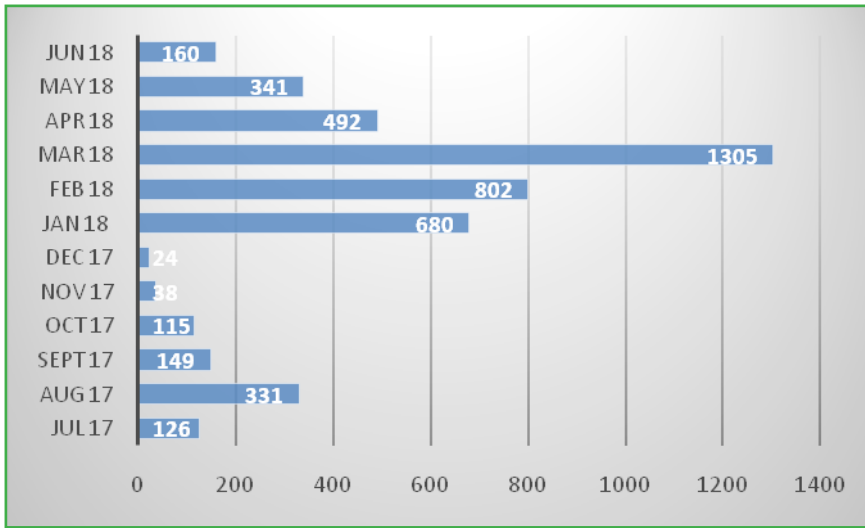


**Fig 3. Showing Full Registration**

**2.8.3 Annual Practicing License (APL).**

In addition to being registered with the council, every practitioner in public or private practice is required to have an annual practicing licence. A total of 4,563 practitioners renewed their licenses from July 2017 to June 2018, which is 74% of the registered practitioners. Council has maintained the requirement for CPDs as basis for granting this license.

Graph 4. Showing APLs issued to practitioners.



#### 2.8.4 Specialist Registration.

UMDPC maintains the specialist register to enable tracking of all the specialists in the Country taking note of those in active practice.

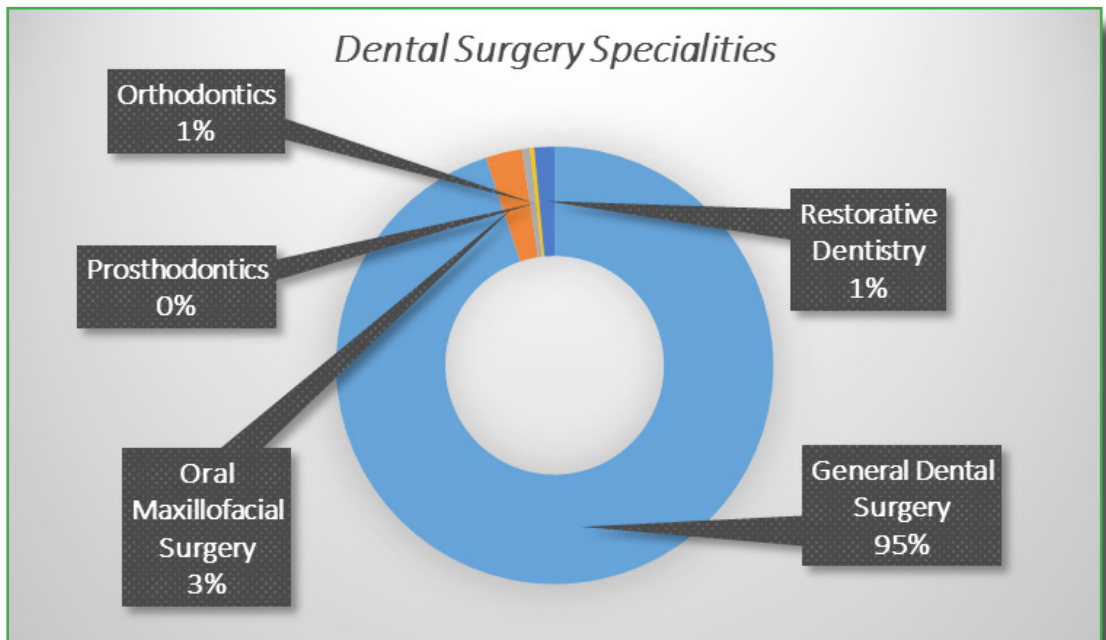
**A total of 149 new specialists were registered at the Council within 2017/2018. It is noted the number of specialists is still low. The percentage of specialists 1,530 to the total number 6,290 is 24%.**

**Council has completed a statutory instrument that will enable it accredit and register collegiate training. This measure will contribute to the increase of training of specialists in the country.**

### Registered and Licenced Medical Specialists

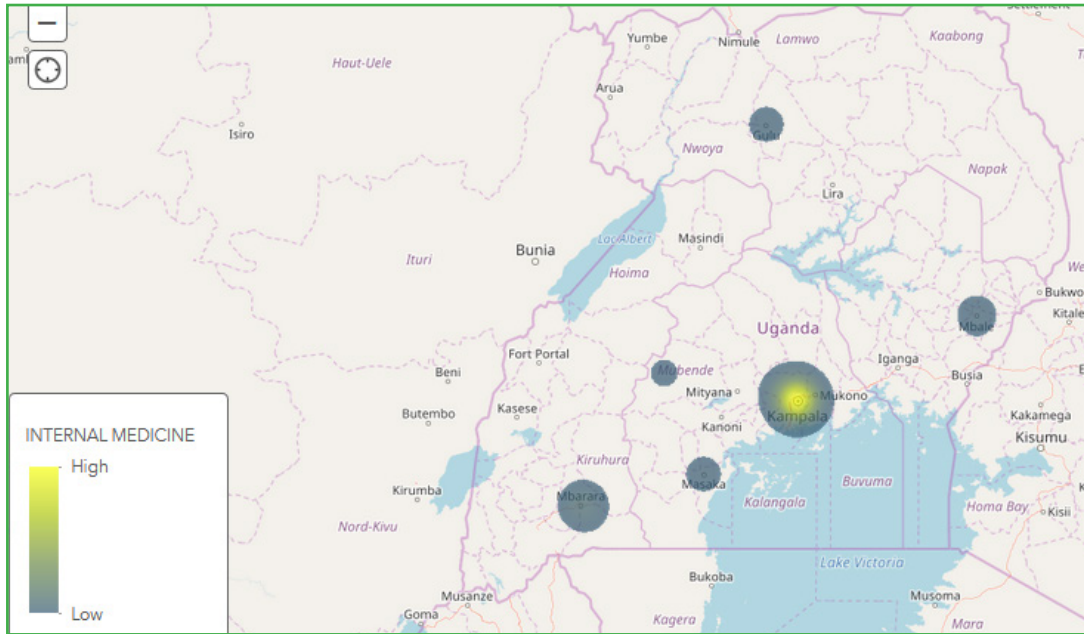


**Fig 3. Showing the profiles of the Dental Profession**

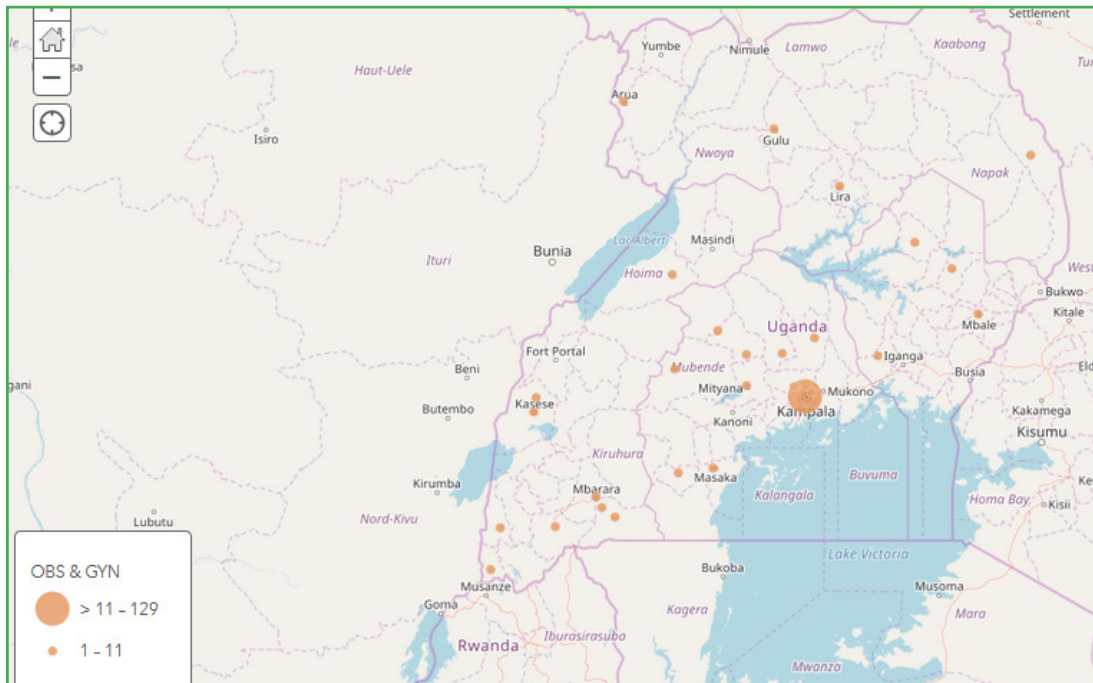


## Distribution of specialists in Uganda.

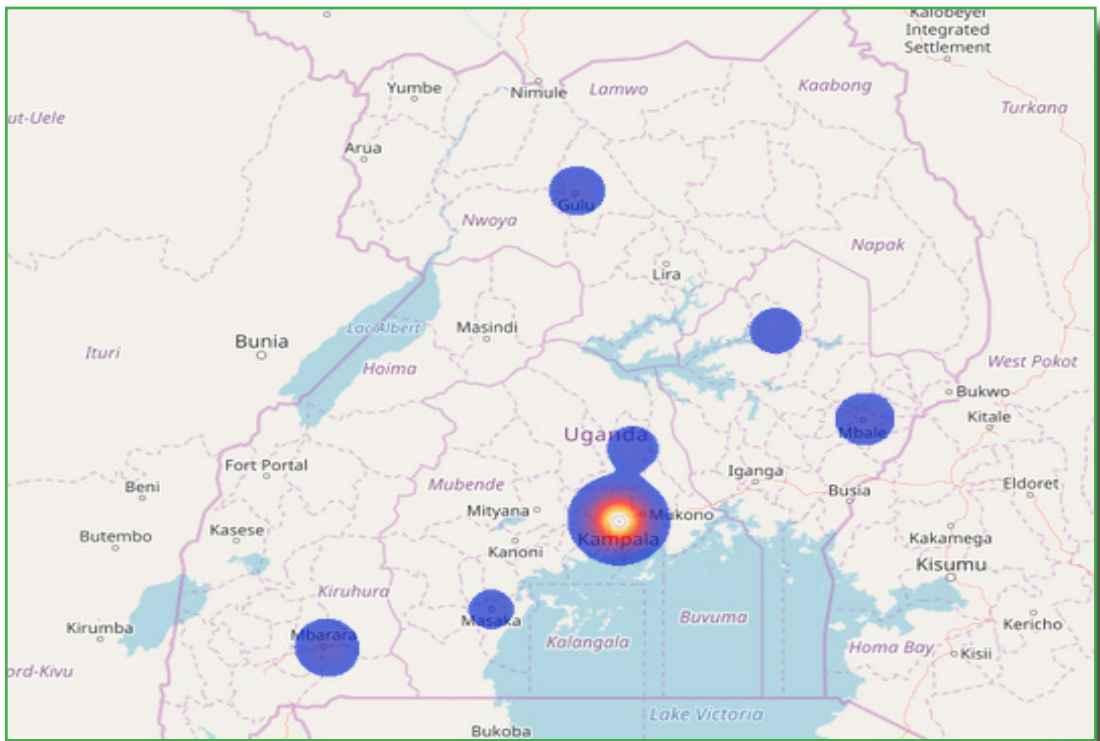
Map 1. Showing distribution of Internal Medical Specialist in Uganda.



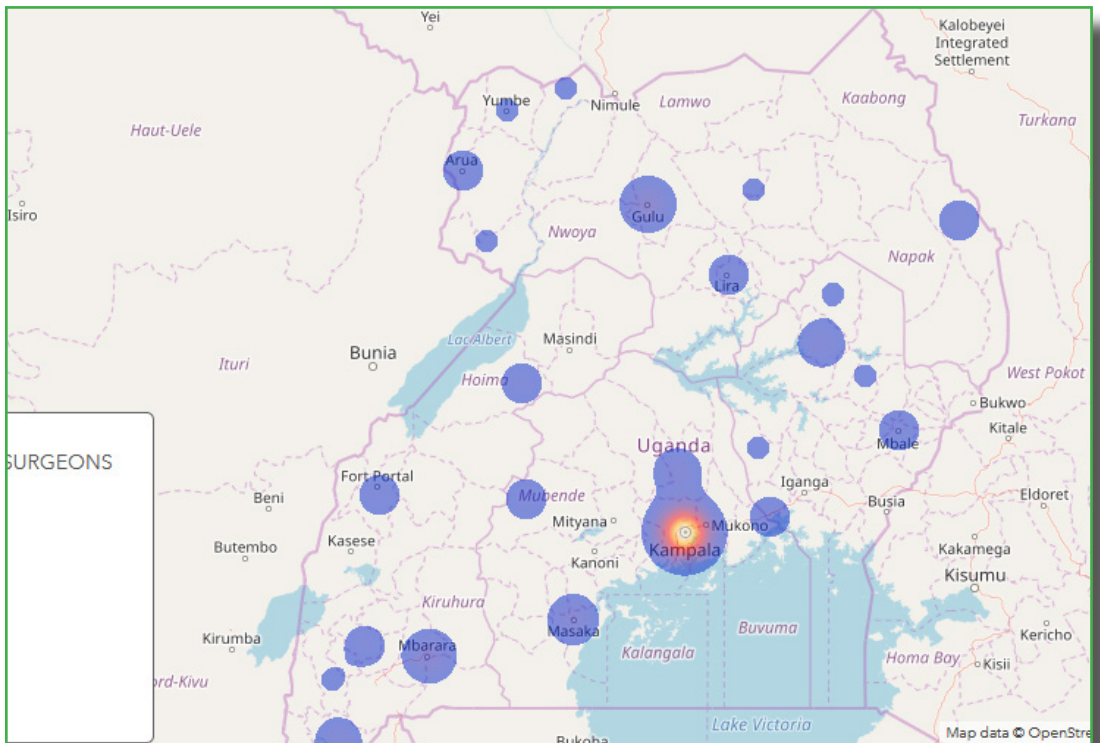
Map 2. Showing distribution of Obstetrics and Gynecology Specialist in Uganda.



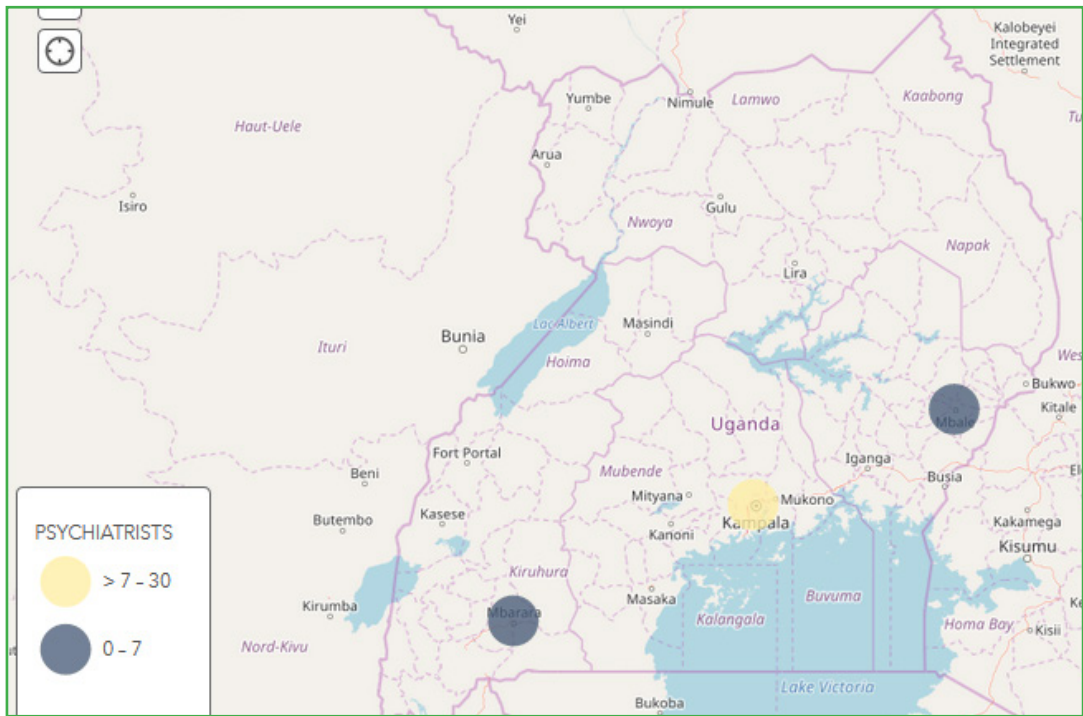
**Map 3. Showing distribution of Paediatrics Specialist in Uganda.**



**Map 4. Showing distribution of general surgeons in Uganda.**



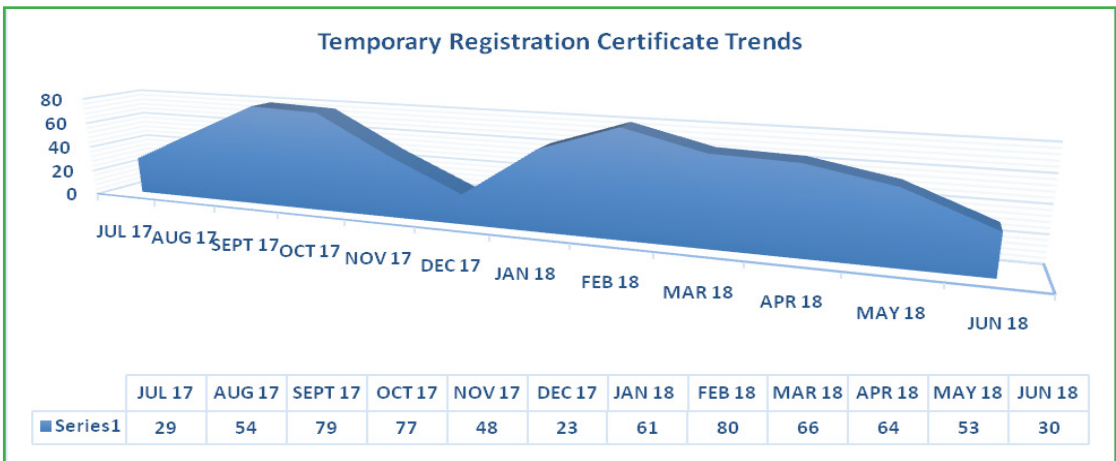
**Map 5. Showing distribution of Psychiatry Specialist in Uganda.**



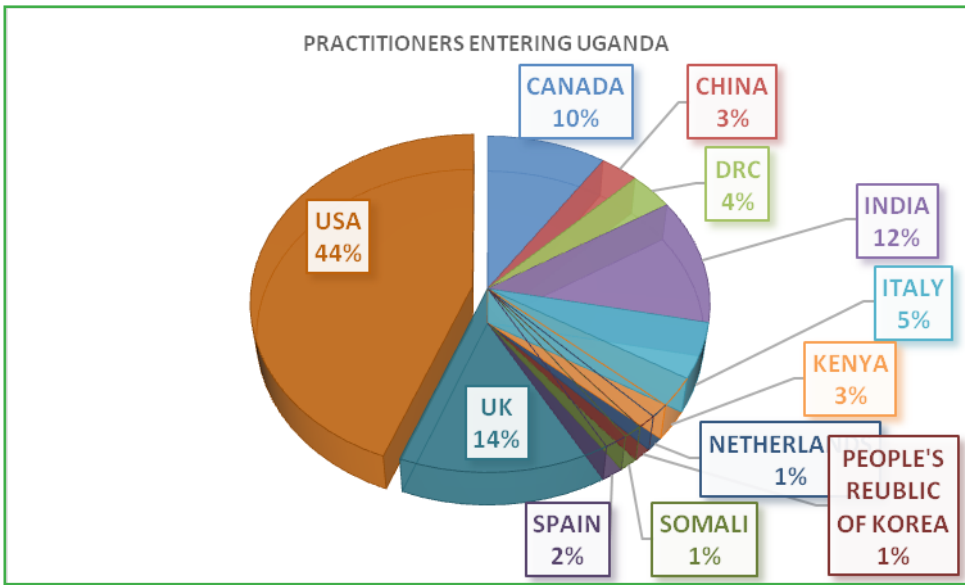
**2.8.4 Temporary Registration**

Between July 2017 to June 2018, a total of 664 foreign practitioners were registered to work in Uganda. Majority of these came for short term assignments and were brought in mainly by the Non-Governmental Sector to support the Health sector in different fields. A few have also been coordinated by Government agencies especially in highly specialized fields like Heart Surgery and Neurosurgery.

**Graph 6. Showing Licensed foreign medical and dental practitioners.**



**Fig 4. Showing origin of foreign practitioners.**



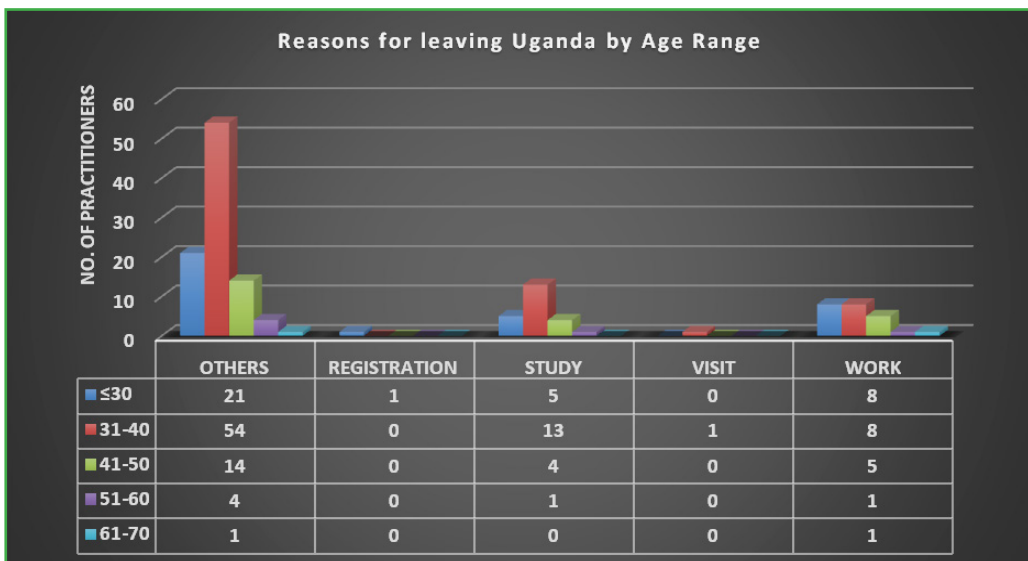
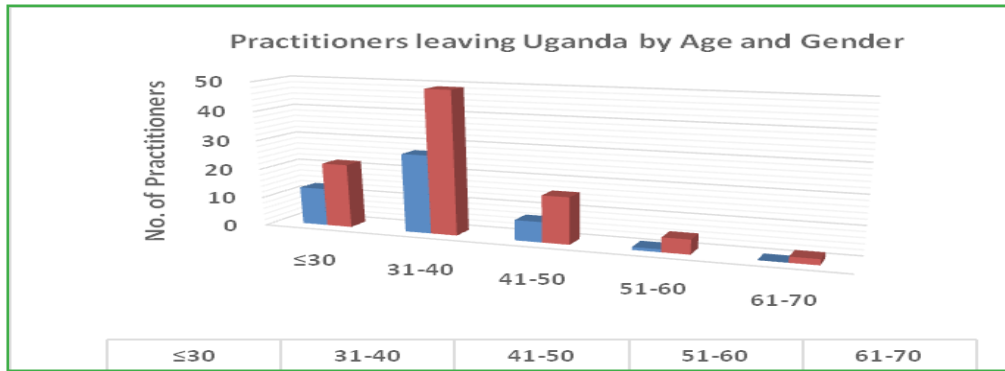
### **2.8.5 Certificate of Good Standing (CGS)**

This register provides up-to date information regarding professional conduct of the practitioner which is documented at the Council.

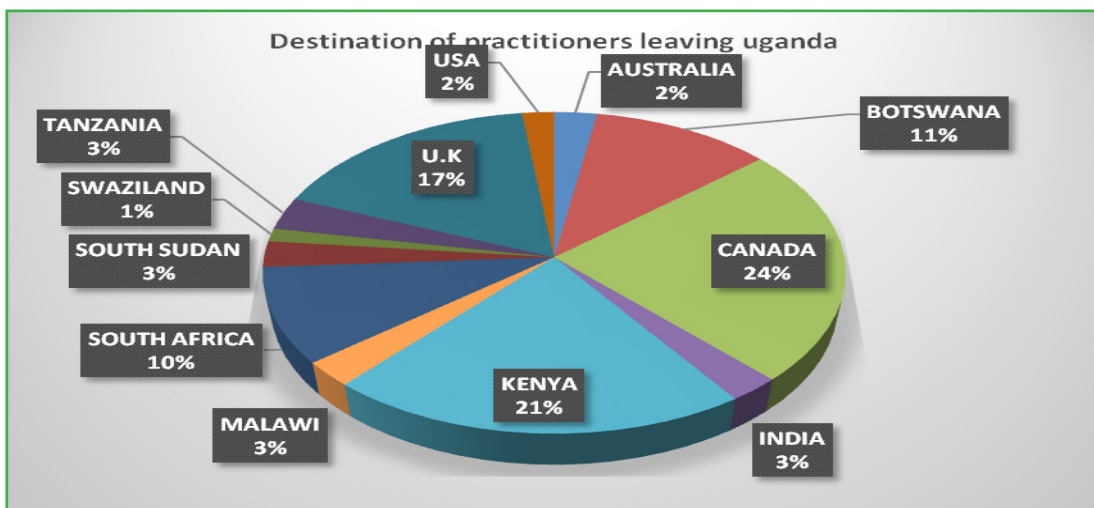
The reason for seeking this certification is to enable the holder to migrate to other countries for various reasons.

A total of 209 practitioners sought for and were granted CGS from July 2017 to June 2018. Their destinations included Southern Africa, East Africa and Europe. There is a considerable number of Practitioners working in South Sudan and Somalia but not captured on the Council database as the States does not require the document. **There is a still a great need to devise measures to curb this brain drain by addressing the push factors notably general working conditions in the Country.**

**Graph 5. Showing Certificate of Good standing certificates issued.**



**Graph 7. Showing Certificate of Good Standing by destination.**

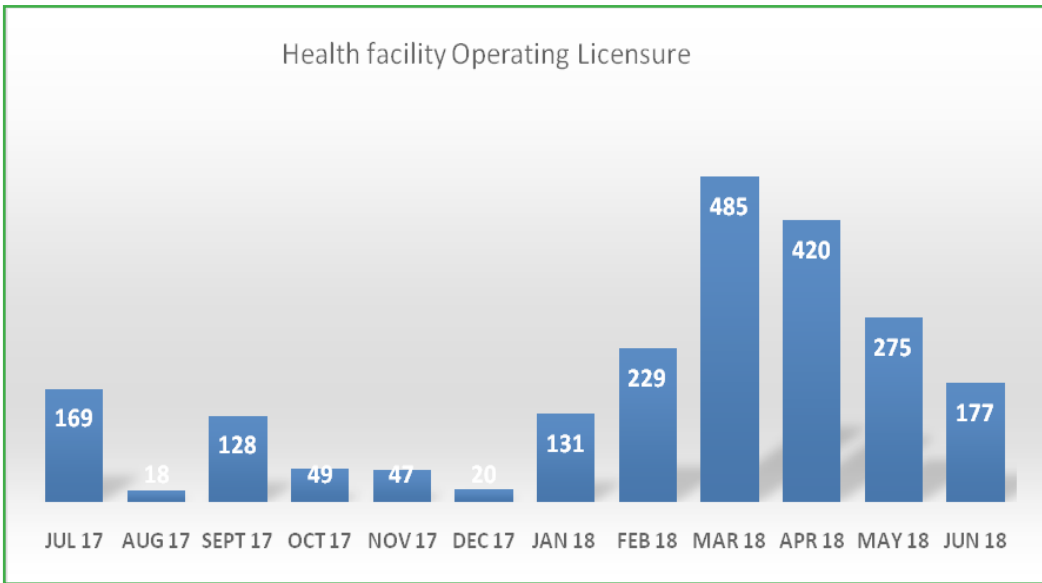


### 2.8.6 Health facility Registration

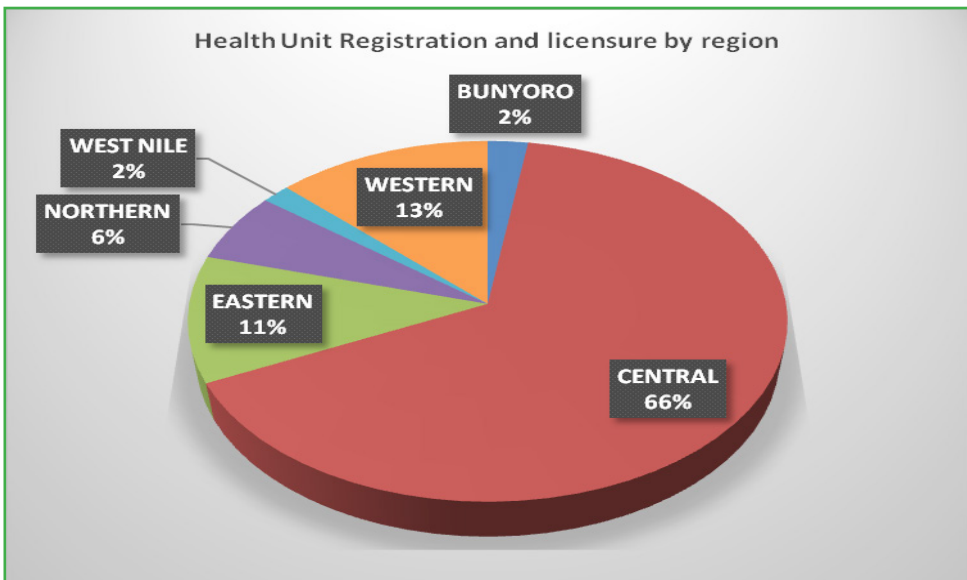
UMDPC has the mandate to register health facilities operated by the Medical and Dental Practitioners, and there after monitor them. The health facilities which register with the Council include Hospitals, medical centres and clinics.

A total of 2,148 Health facilities were licensed by UMDPC between July 2017 to June 2018.

**Graph 6. Showing Operating Licenses issued.**



**Fig 6. Showing Operating Licenses by regions.**



---

## **3.0 Improving policy and regulatory frameworks**

### **3.1 Develop and disseminate regulations:**

Council has continued to produce documents and distributed them free of charge to the practitioners. The documents included UMDPC Act 1996, code of professional ethics, minimum standards of operating a health facility as well guidelines to the public complaining about the doctors' conduct.

These documents are also uploaded on both the Council website as well as the practitioners' individual mails. Additional documents like the clinical guidelines as well as the patients' rights have been sent to the practitioners mails and council website

### **3.2 Reviewing and strengthening the existing guidelines;**

Council, in this reporting period, produced a guideline on medical camps 2017. The objective of this guideline was to regulate the operations of the medical camps in order to provide quality care and safety to patients. Council also launched a communication strategy that will guide this function.

## **4.0 Governance and Management:**

The governance and management of the Council is reflected in the organogram.

### **4.1 Council**

The Council is comprised of 8 members who provide strategic oversight of its regulatory activities. The Council acts as the guardian of the certification process, monitors training and practice by the medical and dental professionals, supervises the secretariat as they issue the certificates and acts as a court of appeal for any aggrieved party.

The Council has relevant committees that handle technical and operational matters in the various functional areas on behalf of the council. These include:

- Finance and Administration
- Education and training
- Inspection and Registration
- Ethics and Disciplinary committee
- Research and Quality Assurance

There are also sub committees that include:

- Medical licensure and examination board
- Fitness to Practice and
- Continuous Professional Development

---

Council and its Committees held meetings during this reporting period and made recommendations and resolutions that were implemented by the secretariat.

## **4.2 Secretariat**

UMDPC has a Secretariat which is responsible for implementation and monitoring of the day to day regulatory operations. Generally, the secretariat implements Council decisions.

## **4.3 Strategic collaborative partnerships and networks established**

### **4.3.1 Enhance Research and documentation at the Council**

Council collaborated with partners to conduct research. In this reporting period the following paper was published whilst some were presented to several fora.

Profile and Causes of Deaths Among Medical Doctors and Dental Surgeons in Uganda. A 29-Year Retrospective Analysis: Jacinto Amandua, Victoria Masebe, Jackson Amone, Katumba Ssentongo Gubala, Peter Mukasa-Kivunike, Fred Nyankori.

Ethical and disciplinary cases at UMDPC 2013-2018: Katumba Ssentongo Gubala, Lwoto Augustine.

The status of Uganda Medical and Dental Practitioners Council as at 2018: Katumba Ssentongo, Lwoto Augustine

UMDPC is working with the Ministry of Health to develop and finalize the following documents:

- National referral guidelines 2018
- Medical tourism guidelines
- Assisted Reproductive Health Technology guidelines

### **4.3.2 Support to the Registrars Forum**

Council continues to support joint programmes with other Health Professional Councils (Nurses and Midwifery, AHPC and Pharmacy Board). This forum promotes joint inspections, decisions and donor coordination. UMDPC still holds the chair of this forum.

Council, in this reporting period, jointly visited the prisons and all the facilities in the refugee camps in Northern and Western Uganda.

---

### **4.3.3 Establishment of National Health Professions Authority (NHPA).**

Council continues to follow up on the establishment of the National Health Professions Authority. This body will bring together all agencies together and this will boost advocacy and operations of the regulatory function of the Ministry of Health.

The draft principles of the national health professional authority has been prepared and is in the pipeline for consideration by Parliament.

### **4.3.4 National networks.**

The following are the major National collaborators of the Council;

- Allied Health Professionals Council
- Uganda Nurses and Midwives Council
- Pharmacy Board
- Uganda Medical Association and Associates
- Uganda Dental Association
- The Pharmaceutical Society of Uganda
- Uganda Private Practitioners Association
- National Drug Authority
- Uganda Healthcare Federation
- Uganda Registration Services Bureau
- National Council for Higher Education
- Centre for Health and Development (CEHUD) Universities and other training institutions.

### **4.3.5 Strengthening human resources for health (SHRH)**

This USAID has supported the professional health Councils in the following arena;

- Facilitated the development and dissemination of the District Health Supervisory Authority guidelines.
- Facilitation of stakeholders meeting for the disseminating council documents and tools.
- The Council is also working with other professional bodies in streamlining collegiate training.

---

#### **4.3.6 IFC-WORLD BANK /ACHEST**

UMDPC has continued working with IFC-WORLD BANK/ ACHEST to complete the process of online licensing.

#### **4.3.7 Regional networks**

The following are the regional collaborators of the Council;

- Kenya Medical Practitioners and Dentists Board (KMDPB)
- Medical Council of Tanganyika (MCT)
- Rwanda Medical and Dental Council (RMDC)
- Burundi Medical Council (BMC)

Council has participated several East African and African meetings which targeted improving its capacity. The East African members set out the best practice principal where partner states were invited to appreciate and apply an innovation that may have worked in a particular Country. In this year, Council with other councils in EAC Partner states completed Mutual Recognition agreement that will enable free movement of professionals in the region.

On top, the East African Medical Councils/Boards revised and produced the inspection guidelines and checklists for Medical and Dental schools and training institutions in the East African region.

Among the activities of the EAC joint Councils/Boards this FY, the partner states exchange the status of reciprocal recognition from 2010 to date here attached as Annex III.

#### **4.3.8 Cooperation with other international agencies**

The following are the regional collaborators of the Council;

- Association of Medical Councils of Africa
- International Medical Regulators Association
- Health Professional Council of Zambia
- Health Professional Council of South Africa

#### **4.3.7.1 Association of Medical Councils of Africa (AMCOA).**

UMDPC is a member of this Regional forum which brings together regulators on the African continent. Council attends an annual meeting. In this reporting period, the meeting was held in Malawi where draft proposal on medical litigation was launched.

AMCOA also completed protocols on internship, governance, litigation for use by member states. These meetings were conducted in Kigali, Rwanda and Pretoria, South Africa.



***AMCOA annual meeting in Cape Town, South Africa 2017***

#### ***4.3.7.2 International Association of Medical Regulatory Association (IAMRA).***

Council continues to interact with other international regulatory agencies and sharing protocols as well as presenting papers. This is a meeting that takes place every two years. The last one was held in Melbourne and the next one was held in Dubai in October 2018.

---

## ANNEX 1. COUNCIL DOCUMENTS

- Medical and Dental Practitioners Act, 1998
- Code of Professional Ethics 2008 (Revised)
- Guidelines in respect to complaints against Medical and Dental Practitioners 2008 (Revised)
- CPD Guidelines 2017(Revised)
- Private Sector inspection tool (SQIS), 2017 (Revised)
- Inspection guidelines 2015
- Fitness to practice guidelines 2016
- MLEB Guidelines 2017 (Revised)
- Medical Camps guidelines 2017
- Guideline on establishment of health facilities,2002
- Application forms for health facility and professional licensure
- Ethics and disciplinary cases at UMDPC 2013-18
- Status of the UMDPC as at 2018

---

**ANNEX 2. UMDPC REGIONAL OFFICES & DISTRICTS.**

|    | <b>REGION</b>  | <b>DISTRICTS</b>  |
|----|----------------|---|
| 1  | BUGISU         | MBALE,SIRONKO,BUDUDA,MANAFWA,<br>BULAMBULI  |
| 2  | BUKEDI         | TORORO,BUSIA, BUTALEJA,KIBUKU,BUDAKA,PALIISA  |
| 3  | BUSOGA         | JINJA,KAMULI,IGANGA, LUUKA, KALIRO, MAYUGE,<br>NAMAYINGO, NAMUTUMBA, BUYENDE, BUGIRI                        |
| 4  | TESO           | AMURIA,KUMI,SOROTI,BUKEDEA,NGORA  |
| 5  | BUNYORO        | HOIMA,BULIISA,MASINDI,KIRYANDONGO,  |
| 6  | KIGEZI         | KABALE,RUKUNGIRI,KISORO, RUBANDA,KANUNGU  |
| 7  | LANGO          | LIRA,OTUKE,OYAM,APAC,DOKOLO,AMOLATAR<br>ALEBTONG, KOLE, ALEBTONG  |
| 8  | ACHOLI         | GULU,AMURU,NWOYA,KITGUM,PADER,OMORO,  |
| 9  | KAMPALA METRO  | KAMPALA,WAKISO AND MUKONO   |
| 10 | BUGANDA        | BUIKWE MASAKA, RAKAI, KALUNGU,<br>LUWEERO, SEMBABULE, GOMBA, BUTAMBALA,<br>NAKASONGOLA, NAKASEKE KALANGALA, |
| 11 | KARAMOJA/SEBEI | KAABONG, ABIM, NAKAPIRIPIT, MOROTO,<br>KAPCHWORA, KWEEN, BUKWO, KOTIDO                                      |

**ANNEX 3. LIST OF PROVISIONALLY ACCREDITED CPD PROVIDERS AS AT JUNE 2018.**

| LIST OF CPD PROVIDERS SUBMITTED TO UMDPC |   |                           |                         |  |         |
|--|---|---------------------------|-------------------------|--|---------|
| ORGANISATION                             | CONTACT PERSON  | TELEPHONE                 | EMAIL                   | LOCATION   |         |
| 1  | AAR   | DR. ALEX MUTABAZI         |                         |  | KAMPALA |
| 2  | AFRICAN ONLINE SCIENTIFIC INFORMATION SYSTEMS LTD (AOSIS) | MRS. JOLETA VAN WYK       | 0861 000 381            | info@aosis.co.za   |         |
| 3  | AGA KHAN HEALTH SERVICES, UGANDA                          |                           | 414259186               |  | KAMPALA |
| 4  | ALIVE MEDICAL SERVICES                                    | DR. PASQUINE N. OGUNSANYA | 0414 258580             | <a href="mailto:admin@amsuganda.org">admin@amsuganda.org</a> | KAMPALA |
| 5  | AMISOM LEVEL 2  | JAMES KIYENGO             | 252 615 744 355         | kiyengo2@yahoo.com   | SOMALIA |
| 6  | ASSOCIATION OF ANESTHESIOLOGISTS OF UGANDA                | DR. ARTHUR KWIZERA        | 0779 229 920            | infor@aaau-online.org  | KAMPALA |
| 7  | ASSOCIATION OF OBSTRETRICIANS & GYNAECOLOGISTS OF UGANDA  | DR. CHARLES KIGGUNDU      | 0414533451 / 0772642841 | gynuganda@yahoo.com  | KAMPALA |
| 8  | ASSOCIATION OF PHYSICIANS OF UGANDA                       | DR. SSEKASANVU EMMANUEL   | 0772468045 / 0712344754 | ecsacop@outlook.com  | KAMPALA |
| 9  | ASSOCIATION OF RADIOLOGISTS OF UGANDA                     | DR. BUGEZA SAMUEL         | 0414 530 137            | <a href="mailto:sambugeza@gmail.com">sambugeza@gmail.com</a> | KAMPALA |
| 10                                       | BANUTU COMPANY LIMITED                                    | MR. JAMES PENYWI          |                         | jiturmwine@gmail.com   |         |
| 11                                       | BAYLOR COLLEGE OF MEDICINE CHILDRENS FOUNDATION-UGANDA.   | DR. ADEODATA KEKITIINWA   | 0417 119 200            | admin@baylor-uganda.org                                      | KAMPALA |

LIST OF CPD PROVIDERS SUBMITTED TO UMDPC

| ORGANISATION | CONTACT PERSON   | TELEPHONE                            | EMAIL   | LOCATION |
|--------------|--|--------------------------------------|---|----------|
| 12           | BEACOF MEDICAL CENTRE  | DR. UTHUMAN KILIZZA                  | 0703451464/0779147033<br>beacofvacancies@gmail.com  | TORORO   |
| 13           | BENEDICTINE EYE HOSPITAL   | DR. ROBERT MAYEKU                    | 0772 747 282<br>beh.tororo@gmail.com  | TORORO   |
| 14           | BETHESDA HOSPITAL SOROTI LTD   | DR AKURUT ELIZABETH EMUKU            | 0788 162 685<br>info@bethesdahospitalSOROTI.com   | SOROTI   |
| 15           | BMJ LEARNING & BMJ BEST PRACTISE   | KIERAN WALSH                         | 00 44 7539 656 947<br>krmwalsh@bmj.com  |          |
| 16           | BUGOLOBI MEDICAL CENTER  | DR. KAWANGUZI PETER/NALUBALE ROBYNAH | 0772436228/0774936109<br><a href="mailto:kawanguzi@hotmail.com">kawanguzi@hotmail.com</a><br><a href="mailto:grobynah@gmail.com">grobynah@gmail.com</a> | KAMPALA  |
| 17           | BUSITEMA UNIVERSITY FACULTY OF HEALTH SCIENCES                           | DR. PETER OLUPOT-OLLUPOT             |   | TORORO   |
| 18           | BUTABIKA HOSPITAL  | DR. HARRIET BIRABWA-OKETCHO          | 0414 504 376<br>info@butabikahospital.com   | KAMPALA  |
| 19           | CARE LINK UGANDA   | MR. ARTHUR RUTAROH                   | 0789 220914<br>info@carelinkug.com  | KAMPALA  |
| 20           | CASE MEDICAL CENTRE  | DR KWEYAMBA VIANNEY                  | 0782166273/0701045045<br>kwevany@yahoo.com  | KAMPALA  |
| 21           | CHINA UGANDA FRIENDSHIP HOSPITAL – NAGURU                                | DR. KABWERU WILBERFORCE MUSOGA       | 0414 581 159<br>chinauganda2014friendship@gmail.com   | KAMPALA  |
| 22           | COLLEGE OF OPHTHALMOLOGY OF EASTERN, CENTRAL AND SOUTHER AFRICA (COECSA) | DR. IBRAHIM MATENDE                  | information@coecea.org  |          |

LIST OF CPD PROVIDERS SUBMITTED TO UMDPC

| ORGANISATION | CONTACT PERSON  | TELEPHONE               | EMAIL                 | LOCATION   |          |
|--------------|---|-------------------------|-----------------------|--|----------|
| 23           | COLLEGE OF SURGEONS OF THE EAST, CENTRAL, AND SOUTHERN AFRICA (COSECSA) | MS JANE FUALAL          | (+255 27) 254 9362/5  | Po box 1009, Arusha, Tanzania.   | TANZANIA |
| 24           | CORNERSTONE HEALTH CARE LIMITED   | SEMAKULA                | 0776543000/0705543000 |  |          |
| 25           | CURE CHILDRENS HOSPITAL OF UGANDA                                       | TIMOTHY REICKSON        | 0775167525/           | TIM.ERICKSON@cure.org  | MPALA    |
| 26           | DEPARTMENT OF FAMILY MEDICINE - MAKERERE UNIVERSITY                     | DR. BESIGYE INNOCENT    | 0782499852/0700455613 | ibesigye@gmail.com   | KAMPALA  |
| 27           | DEPARTMENT OF RADIOLOGY - MUKCHS  | DR. BUGENZA SAMUEL      | 0414 530 137          | <a href="mailto:sambugeza@gmail.com">sambugeza@gmail.com</a>           | KAMPALA  |
| 28           | DISTRICT HEALTH OFFICE – YUMBE  | DR. YAYI ALFRED         | 0772 535 450          | yayi_alfred@yahoo.co.uk  | YUMBE    |
| 29           | DIVINE MERCY HOSPITAL - FATHER BASH FOUNDATION                          | DR. MWAYENYI GODFREY    | 0772 543 238          | divinemercyhospital2012@yahoo.com                                      |          |
| 30           | DR. WAISWA KASADHAKAWO MUSA   | DR. NSEREKO BADRU TENDO | 772/704636178         | <a href="mailto:musa600@gmail.com">musa600@gmail.com</a>               | KAMPALA  |
| 31           | ELIZABETH GLASER PEDIATRIC AIDS FOUNDATION                              | DR. EDWARD BITARAKWATE  | 0312 264 380          | <a href="mailto:ebitarakwate@pedaids.org">ebitarakwate@pedaids.org</a> | MPARARA  |
| 32           | FERTILITY ENDOSCOPY CLINIC  | DR. PRAKASHA PATEL      | 0414 343 855          | fertilityendoscopy@yahoo.co.in   | KAMPALA  |
| 33           | FLUENT MEDICINE HEALTH CARE CONSULTANCY                                 | MUTYABA INNOCENT        | 0782 722 695          | imutyaba@gmail.com   |          |

LIST OF CPD PROVIDERS SUBMITTED TO UMDPC

| ORGANISATION |   | CONTACT PERSON             | TELEPHONE              | EMAIL  | LOCATION  |
|--------------|---|----------------------------|------------------------|--|-----------|
| 34           | GLAXO SMITHKLINE (GSK) PHARMACEUTICALS          | DR. DAVIS KIBIRIGE         | 0782 393955            | <a href="mailto:davis.x.kibirige@gsk.com">davis.x.kibirige@gsk.com</a>     |           |
| 35           | GULU UNIVERSITY                                 | PROF. EMMANUEL MORO        | 0772404886/0471432096  |  | GULU      |
| 36           | HAFIYA SERVICES (AFRICA) LTD                    | PROF. DONALD HA.AMOKO      | 2782 8005 520          | dr.dha.amoko@gmail.com+  |           |
| 37           | IMAGING THE WORLD AFRICA                        | OWANI COLLINS              | 0312516732/0782442843  | <a href="mailto:callwan2000@gmail.com">callwan2000@gmail.com</a>           | KAMPALA   |
| 38           | INTERNATIONAL HEALTH SCIENCE UNIVERSITY (IHSU). | ASSOC. PROF. ROBERT BASAZA | 0701 428 474           | rbasaza@ihsu.ac.ug   | KAMPALA   |
| 39           | INTERNATIONAL HOSPITAL KAMPALA                  | DR. LUGONE HELEN           | 0779078226/ 0772712121 | hlugone@img.co.ug  | KAMPALA   |
| 40           | ISLAMIC MEDICAL ASSOCIATION OF UGANDA           | PROF. MAGID KAGIMU         | 0782 016 868           | mmkagimu@utlonline.co.ug   | KAMPALA   |
| 41           | JINJA REGIONAL REFERRAL HOSPITAL                | DR. SOPHIE NAMASOPO        | 0434122000/122001      | <a href="mailto:jinja Hosp@utlonline.co.ug">jinja Hosp@utlonline.co.ug</a> | JINJA     |
| 42           | JOINT CLINICAL RESEARCH CENTRE (JCRC)           | NELSON KAKANDE             | 0414201147/48          | nkakande@jrcr.org.ug<br>ckityo@jrcr.org.ug                                 | KAMPALA   |
| 43           | JUBILEE DENTAL CLINIC                           | DR MAGARA JAMES            | 0414344647/0772703050  | jamesmagara@gmail.com  | KAMPALA   |
| 44           | KAGANDO HOSPITAL                                | DR. ROBERT MORRIS          | 0756 898 416           | robjenmor@aol.com  | KASESE    |
| 45           | KAKIRA SUGAR LIMITED HOSPITAL                   | DR. KAWALA BRENDA          | 0750190122/0753569492  | mshakirasugar@gmail.com  | JINJA     |
| 46           | KALANGALA HEALTH CENTRE IV                      | DR. MASIIRA BEN            | 0782 897 922           | <a href="mailto:masiiraben@yahoo.co.uk">masiiraben@yahoo.co.uk</a>         | KALANGALA |

LIST OF CPD PROVIDERS SUBMITTED TO UMDPC

| ORGANISATION | CONTACT PERSON   | TELEPHONE             | EMAIL  | LOCATION  |
|--------------|--|-----------------------|--|-----------|
| 47           | KAMPALA AUDIOLOGY AND SPEECH CENTRE<br>DR. EDWARD TURITWENKA                                       | 414691743/754691743   | <a href="mailto:kascentre@yahoo.co.uk">kascentre@yahoo.co.uk</a>             | KAMPALA   |
| 48           | KAMPALA INTERNATIONAL UNIVERSITY – TEACHING HOSPITAL<br>PROF. SSEBUUFU ROBINSON                    | 0772 507 248          | rssebuufu@gmail.com  | BUSHENYI  |
| 49           | KAMULI MISSION HOSPITAL<br>DR. MULELEDHU ANDREW  | 0751 318 504          | kamuli@ucmb.co.ug  | KAMULI    |
| 50           | KISIIZI HOSPITAL<br>DR. IAN SPILLMAN   |                       |  | KABALE    |
| 51           | KISUBI HOSPITAL<br>ASABA ROBERT  | 0772/0751 393188      | asabdock@gmail.com   | WAKISO    |
| 52           | KITOVU HOSPITAL<br>DR. OPIO MARTIN OTYEK   | 0481432217/0782927834 | kitovu@ucmb.co.ug  | MASAKA    |
| 53           | KIWOKO HOSPITAL<br>DR. JAMES NYONYITONO  | 0772513189/0392904505 | james@kiwokohospital.org   | LUWEERO   |
| 54           | KUMI ORTHOPAEDIC CENTRE<br>DR. JOHN OKURE  | 0752 827 995          | drjohnkure@gmail.com   | KUMI      |
| 55           | KYM NILE INTERNATIONAL<br>DR. MULEMA EDRIINE   | 0777 183 987          | edrinem@gmail.com  | JINJA     |
| 56           | LIFELINK HOSPITAL<br>DR NALULE ZAAM  | 0393292998/0712965505 | drzaam@lifelinkug.com  | KAMPALA   |
| 57           | LUBAGA HOSPITAL<br>DR. WALUGEMBE   | 0414 234 226          | lubaga@lubaga.org  | KAMPALA   |
| 58           | LYANTONDE HOSPITAL<br>DR. OBB OKOTH  | 0752 819372           | <a href="mailto:lyantondehospital@gmail.com">lyantondehospital@gmail.com</a> | LYANTONDE |
| 59           | MAKERERE UNIVERSITY – JOHN HOPKINS UNIVERSITY RESEARCH ORGANISATION (MUJHU)<br>DR. LILLIAN WAMBUZI | 0414 543 002          | lwambuzi@mujhu.org   | KAMPALA   |

LIST OF CPD PROVIDERS SUBMITTED TO UMDPC

| ORGANISATION | CONTACT PERSON   | TELEPHONE                       | EMAIL                 | LOCATION   |         |
|--------------|--|---------------------------------|-----------------------|--|---------|
| 60           | MAKERERE UNIVERSITY - SCHOOL OF BIOMEDICAL SCIENCES - DEPARTMENT OF MEDICAL MICROBIOLOGY | AUGUSTINE KADDU MUSISI SSEVVIRI | 0712800023/0754587457 | kaddu@chs.mak.ac.ug/<br>augkaddu@gmail.com                                   | KAMPALA |
| 61           | MAKERERE UNIVERSITY COLLEGE OF HEALTH SCIENCES   | PROF. HARRIET M. KIZZA          | 0772 593 482          |  | KAMPALA |
| 62           | MAKERERE UNIVERSITY LUNG INSTITUTE   | DR. REBECCA NATANDA             | 0414 699134           | mli@chs.mak.ac.ug  | KAMPALA |
| 63           | MAKERERE UNIVERSITY WALTER REED PROJECT  | TUMUSIIME VICTORIA              | 0312 330 400          | muwvp@muwvp.org  | KAMPALA |
| 64           | MARIE STOPEs INTERNATIONAL UGANDA  | MILTON AWUDO                    | 0759004002/0312263317 | <a href="mailto:milton.awudo@msiu.or.ug">milton.awudo@msiu.or.ug</a>         | KAMPALA |
| 65           | MASAKA REGIONAL REFERRAL HOSPITAL  | DR. ALBERT KAMUGISHA            | 0481660045/0772670950 | albkamugisha@gmail.com   | MASAKA  |
| 66           | MBALE REGIONAL REFERRAL HOSPITAL   | DR. JULIAN ABESO                | 0778 987771           | jabeso@gmail.com   | MBALE   |
| 67           | MBARARA UNIVERSITY OF SCIENCE AND TECHNOLOGY (MUST)                                      | DR MALING SAM                   |                       |  | MBARARA |
| 68           | MENGO HOSPITAL   | DR. KALIBBALA SENGI             | 0774 991 260          | sendikalibbala@gmail.com   | KAMPALA |
| 69           | MILDMAY UGANDA   | EDITH AKANKWASA                 | 0312 210 200          | Edith.akankwasa@mildmay.or.ug  | WAKISO  |
| 70           | MRC/UVRI   | BERNADETTE NAYIGA KALANZI       | 0417704187/0772386579 | <a href="mailto:berna.kalanzi@mrcuganda.org">berna.kalanzi@mrcuganda.org</a> | KAMPALA |

LIST OF CPD PROVIDERS SUBMITTED TO UMDPC

| ORGANISATION | CONTACT PERSON  | TELEPHONE              | EMAIL  | LOCATION |
|--------------|---|------------------------|--|----------|
| 71           | MUBENDE REGIONAL REFERRAL HOSPITAL  | 0774573877/0756573877  | afizikibuuka@gmail.com   | MUBENDE  |
| 72           | MULAGO NATIONAL REFERRAL HOSPITAL   |                        |  | KAMPALA  |
| 73           | NAKASERO HOSPITAL LTD   | 0414346150/2/4         | info@nhl.co.ug   | KAMPALA  |
| 74           | NORVIK HOSPITAL   | 0414346772/0774640620  | <a href="mailto:info@norvikhospital.ug">info@norvikhospital.ug</a> | KAMPALA  |
| 75           | PAN DENTAL ACADEMY  | 0772202525/0701407159  | registrar@pandentalacademy.com                                     | KAMPALA  |
| 76           | PARTNERSHIP FOR DEVELOPMENT & SOCIAL TRANSFORMATION                             | 0712 684 090           | pdst@yahoo.com   |          |
| 77           | REGIONAL CENTRE FOR QUALITY OF HEALTH CARE                                      | 0772 732206            | mail@rcqhc.org   |          |
| 78           | RHEMA MEDICAL GROUP   | 0777363201/07775135353 | anzoism2008@gmail.com  | ARUA     |
| 79           | RUGARAMA HOSPITAL - KABALE  | 0777408890/0704902372  | <a href="mailto:stuart042@gmail.com">stuart042@gmail.com</a>       | KABALE   |
| 80           | SAS CLINIC  | 0772407094/0702704094  | gmtkaisa1967@gmail.com   | KAMPALA  |
| 81           | SOCIAL SERVICES DEVELOPMENT TRUST IN PARTNERSHIP WITH CRANE HEALTH SERVICES LTD | 0312272241/0772301613  | kambasam@yahoo.co.uk   |          |
| 82           | SOCIETY OF UGANDA PRIVATE MEDICAL PRACTITIONERS LTD                             | 0414599908/0752432090  | bayiggalm@yahoo.com  | KAMPALA  |
| 83           | SOROTI REGIONAL REFERRAL HOSPITAL   | 0702 514 615           |  | SOROTI   |

LIST OF CPD PROVIDERS SUBMITTED TO UMDPC

| ORGANISATION  | CONTACT PERSON                | TELEPHONE              | EMAIL  | LOCATION |
|---|-------------------------------|------------------------|--|----------|
| 84 ST. CATHERINE'S HOSPITAL                                     | DR. KAJUMBE MUGANGA           | 0414231534/0782747720  | <a href="mailto:info@stcatherinehospital.co.ug">info@stcatherinehospital.co.ug</a> | KAMPALA  |
| 85 ST. FRANCIS HOSPITAL NSAMBYA                                 | DR. ANTHONY MAKHOBA           | 0414267012/0774981577  | nsambya@ucmb.co.ug   | KAMPALA  |
| 86 ST. MARY'S HOSPITAL LACOR                                    | DR. OPIRA CYPRIAN             | 0471 432 666           | info@lacorhospital.org   | GULU     |
| 87 ST. STEPHEN'S HOSPITAL C.O.U MPERERWE                        | DR. NAKIBUJULE CATHERINE      | 0772695025/0393518512  | <a href="mailto:ststephens@ymail.com">ststephens@ymail.com</a>                     | KAMPALA  |
| 88 THE AIDS SUPPORT ORGANISATION (TASO)                         | DR. BATWALA MOSES             | 0414 532 580/1         | mail@tasouganda.org  | KAMPALA  |
| 89 THE CHILDREN'S CLINIC NAALYA                                 | DR. NAKATO AISHA              | 0772383914/0771 333620 | info@thechildrensclinic.com  | KAMPALA  |
| 90 THE INFECTIOUS DISEASE INSTITUTE                             | DR. SSEKABIRA BYANSANSA UMARU | 0312211422/0772460446  | ussekabira@jdi.co.ug   | KAMPALA  |
| 91 THE MEDICAL CONCIERGE GROUP LTD                              | DR WILLIAM LUBEGA             | 800 100 700            | info@tmcg.co.ug  |          |
| 92 THE SURGERY  | DR. NTAATE CONRAD             | 0312256001/0772256003  | ntaattec@yahoo.com   | KAMPALA  |
| 93 THE UGANDA PRIVATE MEDICAL PRACTITIONERS ASSOCIATION (UPMPA) | DR. KAWANGUZI PETER           | 0772 436 228           | kawanguzi@hotmail.com  | KAMPALA  |
| 94 UGANDA CANCER INSTITUTE                                      | DR. NIXON NIYONZIMA           | 0414540605/0755677395  | nixon.niyonzima@uci.or.ug  | KAMPALA  |
| 95 UGANDA CHRISTIAN MEDICAL FELLOWSHIP                          | DR. AGASHA D. BIRUNGI         | 0787 535667            | ugandacmf@gmail.com  |          |

LIST OF CPD PROVIDERS SUBMITTED TO UMDPC

| ORGANISATION                              | CONTACT PERSON                | TELEPHONE             | EMAIL  | LOCATION |
|---|-------------------------------|-----------------------|--|----------|
| 96 UGANDA DENTAL ASSOCIATION              | DR. EDWARD KALYESUBULA        | 0702 843 944          | ugdental@gmail.com   | KAMPALA  |
| 97 UGANDA DIABETES ASSOCIATION            | DR. NAKIREKA SUSAN TUMWESIGYE | 0772591911/0775596549 | ugandadiabetes@gmail.com   | KAMPALA  |
| 98 UGANDA FERTILITY SOCIETY               | RUJUMBA DAVIS                 | 0772 905 452          | <a href="mailto:aruumba@gmail.com">aruumba@gmail.com</a>             | KAMPALA  |
| 99 UGANDA HEALTH CARE FEDERATION          | NINA KARAMUKYO                | 0751903646/0777062087 | info@uhfug.com   | KAMPALA  |
| 100 UGANDA HEART ASSOCIATION              | DR. EMMY OKELLO               | 0775 522 284          | emmykol@hotmail.com  | KAMPALA  |
| 101 UGANDA HEART INSTITUTE                | MICHAEL CHARLES OKETCHO       | 0417720350/0417720377 |  | KAMPALA  |
| 102 UGANDA MARTYRS' HOSPITAL IBANDA       | DR. BYARUHANGA EMMANUEL       | 0772 460945           | ibandahospital@yahoo.com<br>ibanda@ucmb.co.ug                        | IBANDA   |
| 103 UGANDA MEDICAL ASSOCIATION            | DR. NATHAN KENYA-MUGISHA      | 0772 731 751          | <a href="mailto:nkenyamughisa@yahoo.com">nkenyamughisa@yahoo.com</a> | KAMPALA  |
| 104 UGANDA MUSLIM MEDICAL BUREAU          | DR. KARAMA SAID ALI           | 0414 576430           | <a href="mailto:ummmb@utlonline.co.ug">ummmb@utlonline.co.ug</a>     | KAMPALA  |
| 105 UGANDA PAEDIATRIC ASSOCIATION         | TUMWINE DANIEL                | 0772 383 914          | danieltumwine@gmail.com  | KAMPALA  |
| 106 UGANDA PEOPLES' DEFENCE FORCES (UPDF) | DR NANGAMBA RONALD            | 0704 935 461          | nangamba@yahoo.co.uk   | LUWEERO  |
| 107 UGANDA PROTESTANT MEDICAL BUREAU      | DR. TONNY TUMWESIGYE          | 0414 271 776          | <a href="mailto:upmbadmin@upmb.co.ug">upmbadmin@upmb.co.ug</a>       | KAMPALA  |

LIST OF CPD PROVIDERS SUBMITTED TO UMDPC

| ORGANISATION  | CONTACT PERSON                            | TELEPHONE             | EMAIL  | LOCATION |
|---|---|-----------------------|--|----------|
| 108 UGANDA SOCIETY FOR ADVANCEMENT OF RADIOLOGY AND IMAGING (USOFARI) | DR. ZERIDAH MUYINDAH                      | 0414530137/0772432796 | zeridahm@yahoo.com   | KAMPALA  |
| 109 UMC VICTORIA HOSPITAL   | DR. NANJERU LALA KWAGALA DR BAGASHA PEACE | 0787 710193           | ninnlucy@gmail.com   | KAMPALA  |
| 110 UNIVIC MEDICAL CENTRE   | DR. DAVID MAGOBA                          | 0417727101/0700693840 | info@umchospitals.com  | KAMPALA  |
| 111 UPDF - SPECIAL FORCES COMMAND                                     | DR. AMANYA COLLINE                        | 0414 320017           | <a href="mailto:medicalsf@gmail.com">medicalsf@gmail.com</a>                   | LUWEERO  |
| 112 URO CARE HOSPITAL   | DR. MALE KAWUMA                           | 771656776/393262132   | <a href="mailto:ca@urocareuganda.org">ca@urocareuganda.org</a>                 | WAKISO   |
| 113 VILLA MARIA HOSPITAL  | DR. CHRS KAGANDA                          |                       | villamaria@ucmb.co.ug  | MASAKA   |
| 114 WATOTO  | NAGADYA JULIET                            | 0788706872/078242529  | happy.byereta@watotochurch.com   | KAMPALA  |
| 115 WENTZ MEDICAL CENTRE  | DR. E. TAMALE SSALI                       | 0703 999220           | <a href="mailto:julie@wentzmedicalcenter.org">julie@wentzmedicalcenter.org</a> | KAMPALA  |
| 116 WOMEN'S HOSPITAL INTERNATIONAL KAMPALA                            | OGULE JACOB                               | 0414541361/0772520248 | <a href="mailto:rvilavil@womenshospital.net">rvilavil@womenshospital.net</a>   | KAMPALA  |
| 117 YUMBE HOSPITAL  |   | 0772 575 141          | maloryweis@gmail.com   | YUMBE    |



